

INTERSTOP®

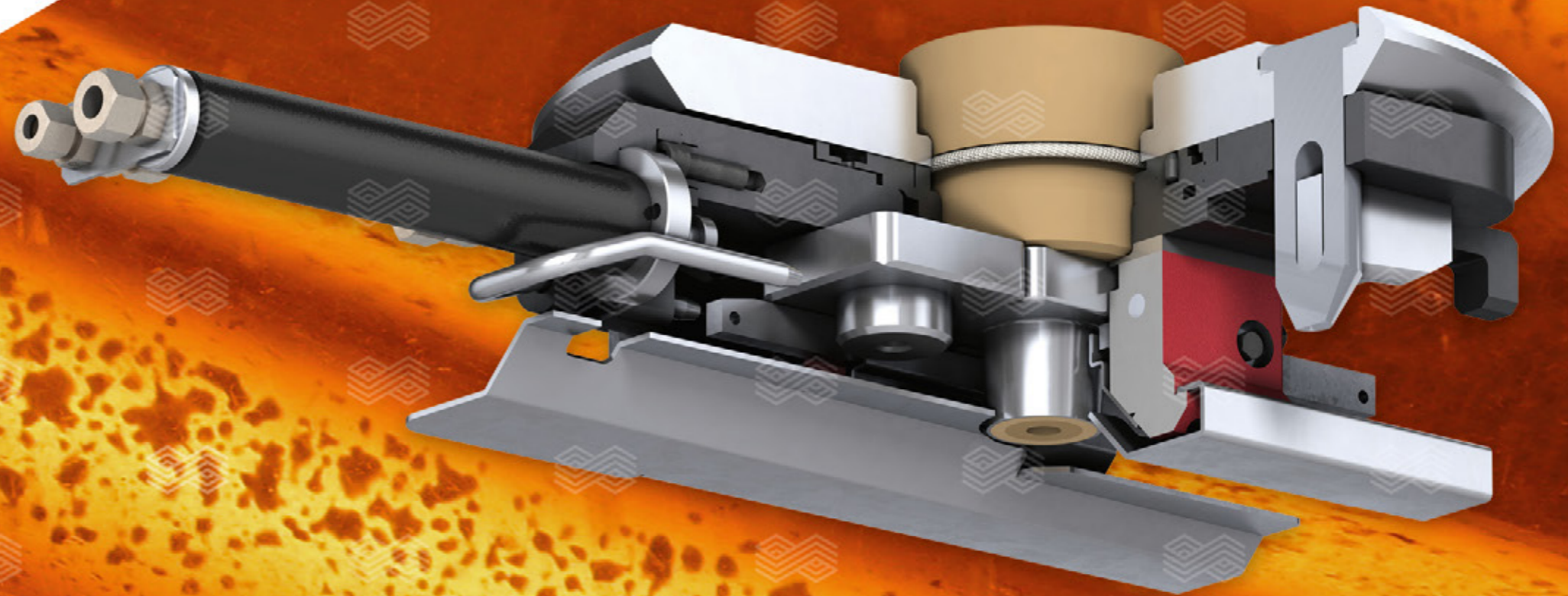

STEEL / FLOW CONTROL TECHNOLOGY

Metering Nozzle Changer INTERSTOP® MNC-AS



Metering Nozzle Changer INTERSTOP® MNC-AS

Overview

- For reliable and safe long sequence casting
- Sliding drive arrangement
- Same plate fixation as tundish and emergency gate
- Optional submerged nozzle application

System Characteristics

- Mechanical fixation of upper nozzle
- Clear view to the nozzle & mold
- Springs well protected for long service life
- Compact dimensions
- Optional submerged nozzle application

Refractory Parts

- Pressed and fired upper nozzle designed for long sequences
- Mechanical fixation of the upper nozzle
- Wide refractory portfolio

Maintenance and Support

- Minimal maintenance work required
- Long lifetime of parts
- Long inspection intervals, short inspection time
- INTERSTOP® after sales service

Main Parts

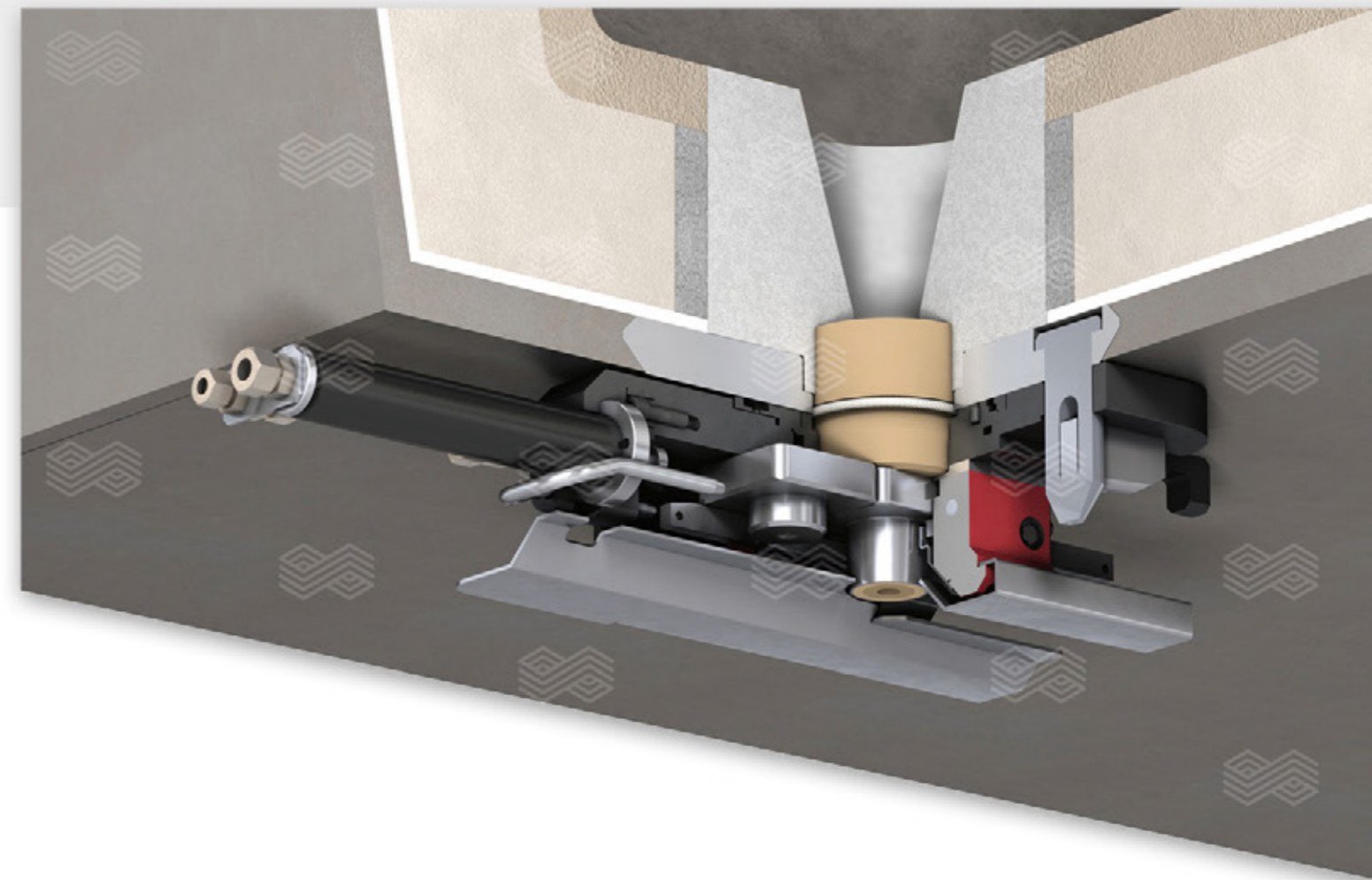
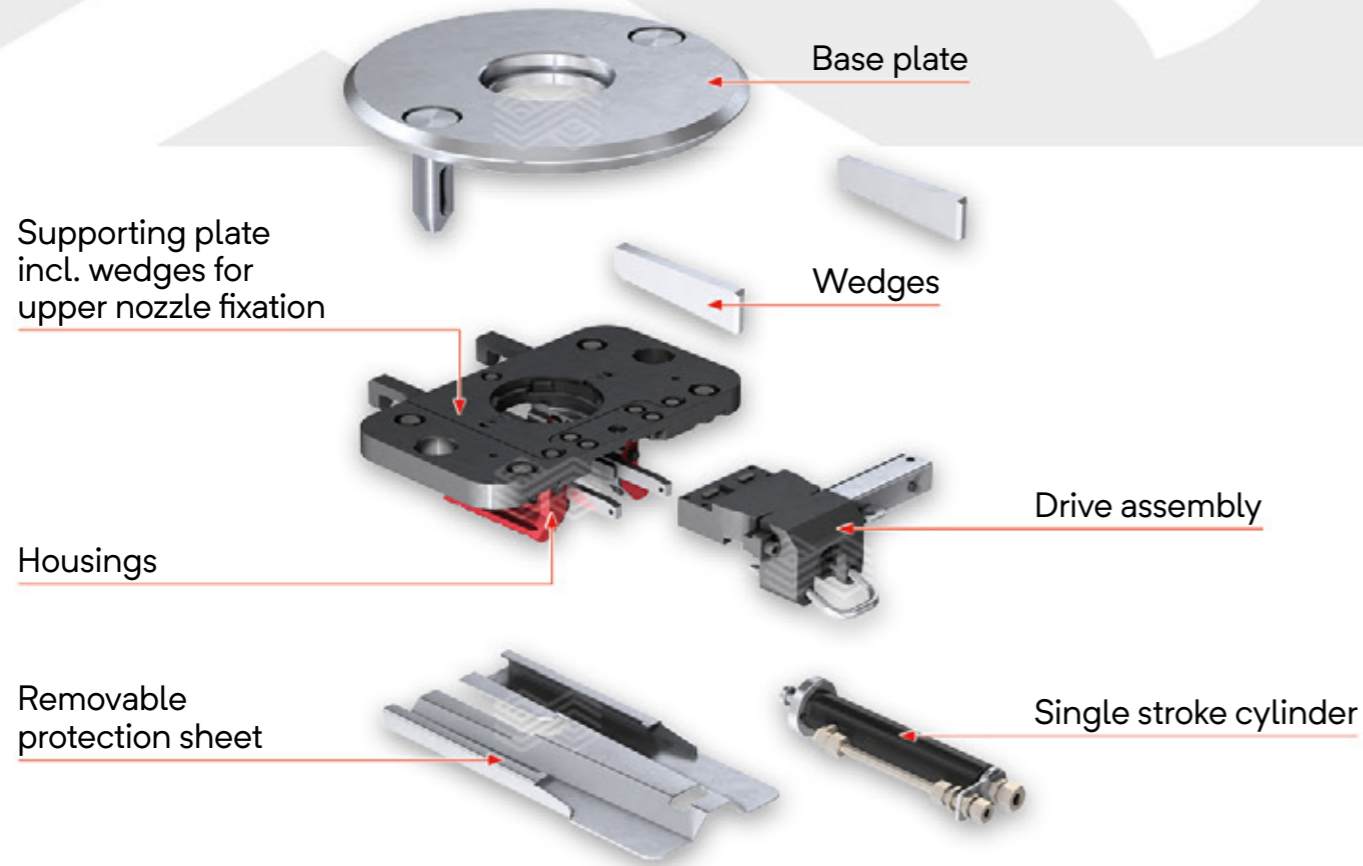

Tundish



Video



Imprint:

Media owner and publisher: RHI Magnesita GmbH, Kranichberggasse 6, 1120 Vienna, Austria

Produced by: RHI Magnesita — 02 / 2020-EN

Place of publication and production: Vienna, Austria



Copyright notice:

The texts, photographs and graphic design contained in this publication are protected by copyright. Unless indicated otherwise, the related rights of use, especially the rights of reproduction, dissemination, provision and editing, are held exclusively by RHI Magnesita. Usage of this publication shall only be permitted for personal information purposes. Any type of use going beyond that, especially reproduction, editing, other usage or commercial use is subject to explicit prior written approval by RHI Magnesita.

Stopinc Aktiengesellschaft

Bösch 83a, 6331 Hünenberg, Switzerland

T +41 41 785 75 00

E interstop@rhimagnesita.com

RHI TRADING (DALIAN) CO., LTD

Shanghai Branch

Rm. 1803 Lippo Plaza, No. 222 Huaihai (M) Rd. 200021 Shanghai, P. R. China

T +86 21 23199507

E interstop@rhimagnesita.com

RHI US LTD.

3956 Virginia Avenue, Cincinnati, Ohio 45227 USA

T +1 513 527 6160

E interstop@rhimagnesita.com

RHI Magnesita GmbH

Kranichberggasse 6, 1120 Vienna, Austria

T +43 50213 0

E steel@rhimagnesita.com

rhimagnesita.com

The Journal of
Refractory Innovations

bulletin

Subscriptions
Service and
Contributions

