



RHI MAGNESITA

GLASS / REFRACTORY MATERIALS

# Feuerfestlösungen für die Glasindustrie

—

## Refractory Material Solutions for the Glass Industry



# There for you, wherever you need us



The more closely we work with our customers, the greater the difference we can make for them. So having a global network of offices, research centers and production sites is important to us, and to them. We'll go on extending our global reach, to be nearer to even more customers.

Being closer to customers doesn't just mean we can be more responsive to their needs. It also helps us to listen better — to understand their concerns, cultures and ways of working. And to be alert to new thinking and ideas that enable us to deliver ever better advice, service and solutions.

Our exceptional resources and expertise extend far beyond making and selling products. We also provide solutions to customers worldwide for cover projects, materials specification, thermal studies, numerical simulations, follow-up and technical support in application of minerals, and maintenance and electromechanical services for refractory equipment.

RHI Magnesita concentrates its worldwide activities for the glass industry in the Business Unit Industrial Projects and offers customized all-inclusive solutions which additionally include sustainability goals, such as:

- resource-saving production to protecting the environment
- energy-efficient lining concepts for the customers
- Manufacturing in accordance with ISO-certified environmental and quality assurance standards in all our plants worldwide.
- Reduction of CO<sub>2</sub> emissions



**47**  
Main production sites



**+170**  
Countries shipped to worldwide



**12**  
Raw material sites



**5**  
R&D hubs and centers

# Content

## Refractory Material Solutions for the Glass Industry

- Container Glass Tank for Flint Glass
- Container Glass Tank for Colored Glass
- Fiberglass Tank
- Float Glass Tank
- Tin Bath Bottom
- Casing
- INNOREG — Standard Configuration
- INNOREG — Anti-Clogging Configuration
- Checker Brick Shapes
- Rider Arch and Transition Tiles
- Customer-oriented System Solutions — Ceramic Superstructure
- Complex Geometries for Special Applications
- Customer-oriented System Solutions — Energy Efficiency
- Monolithic Concept
- Honeycomb Design
- Epsilon Concept
- Bottom Concept
- Tolerances
- Service Offers





# Behälterglaswanne für Farbglass

# Container Glass Tank for Colored Glass

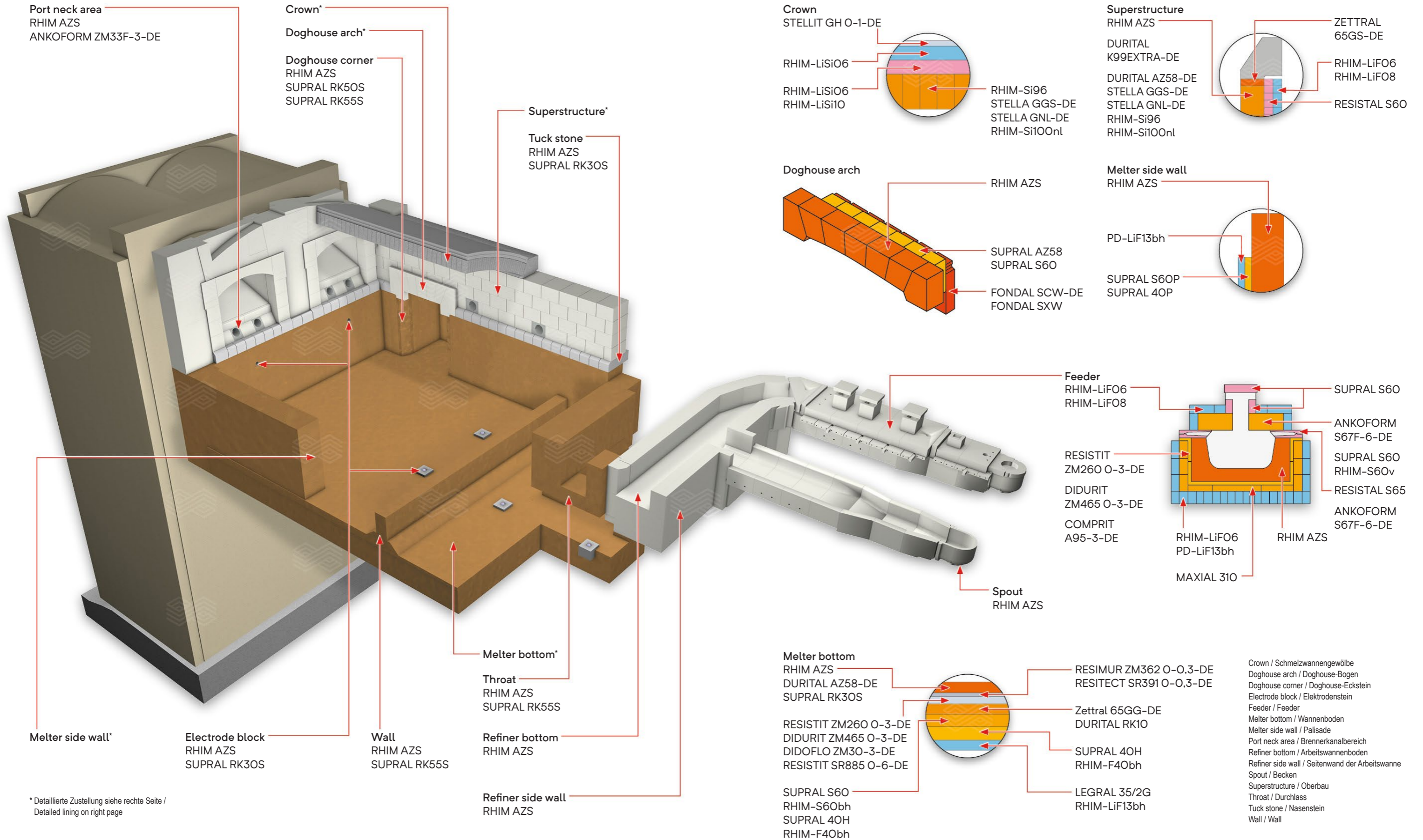

\* Detaillierte Zustellung siehe rechte Seite /  
Detailed lining on right page

# Faserglaswanne

# Fiberglass Tank

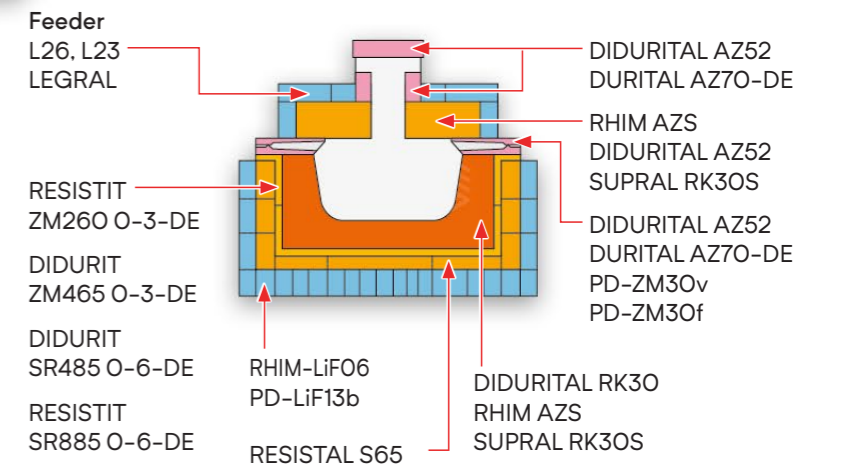
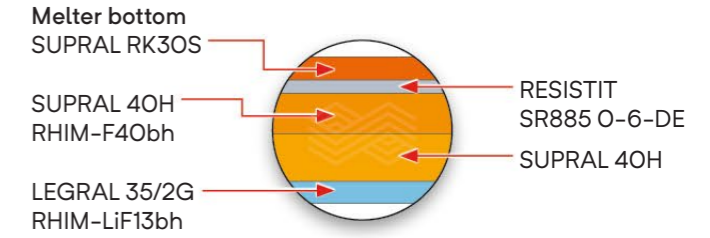
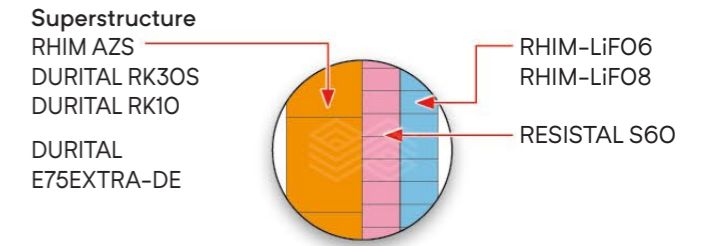
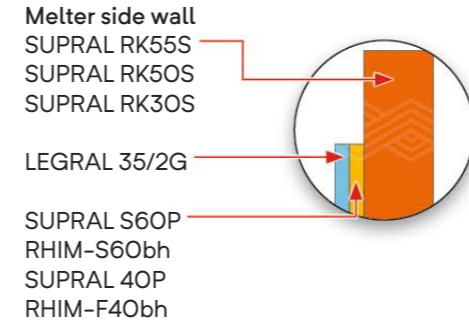
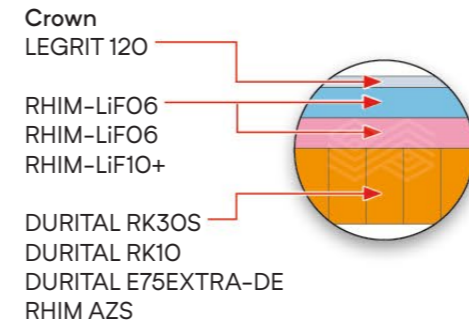
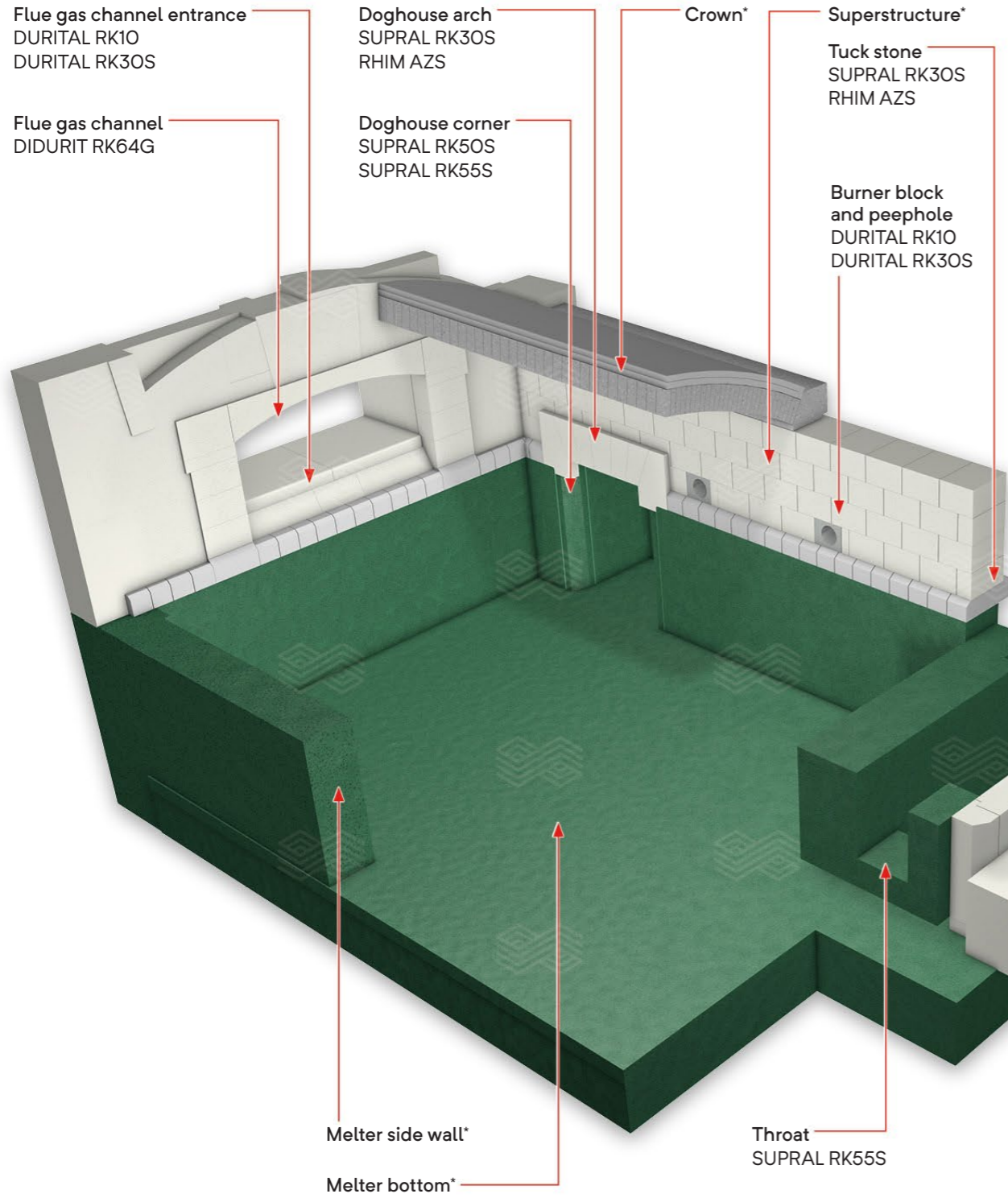

Burner block and peephole / Brennerstein und Schauloch  
Crown / Schmelzwannengewölbe  
Doghouse arch / Doghouse-Bogen  
Doghouse corner / Doghouse-Eckstein  
Feeder / Feeder  
Flue gas channel / Abgaskanal  
Flue gas channel entrance / Eingang Abgaskanal  
Melter bottom / Wannenboden  
Melter side wall / Palisade  
Superstructure / Oberbau  
Throat / Durchlass  
Tuck stone / Nasenstein

\* Detaillierte Zustellung siehe rechte Seite / Detailed lining on right page

# Floatglaswanne

# Float Glass Tank

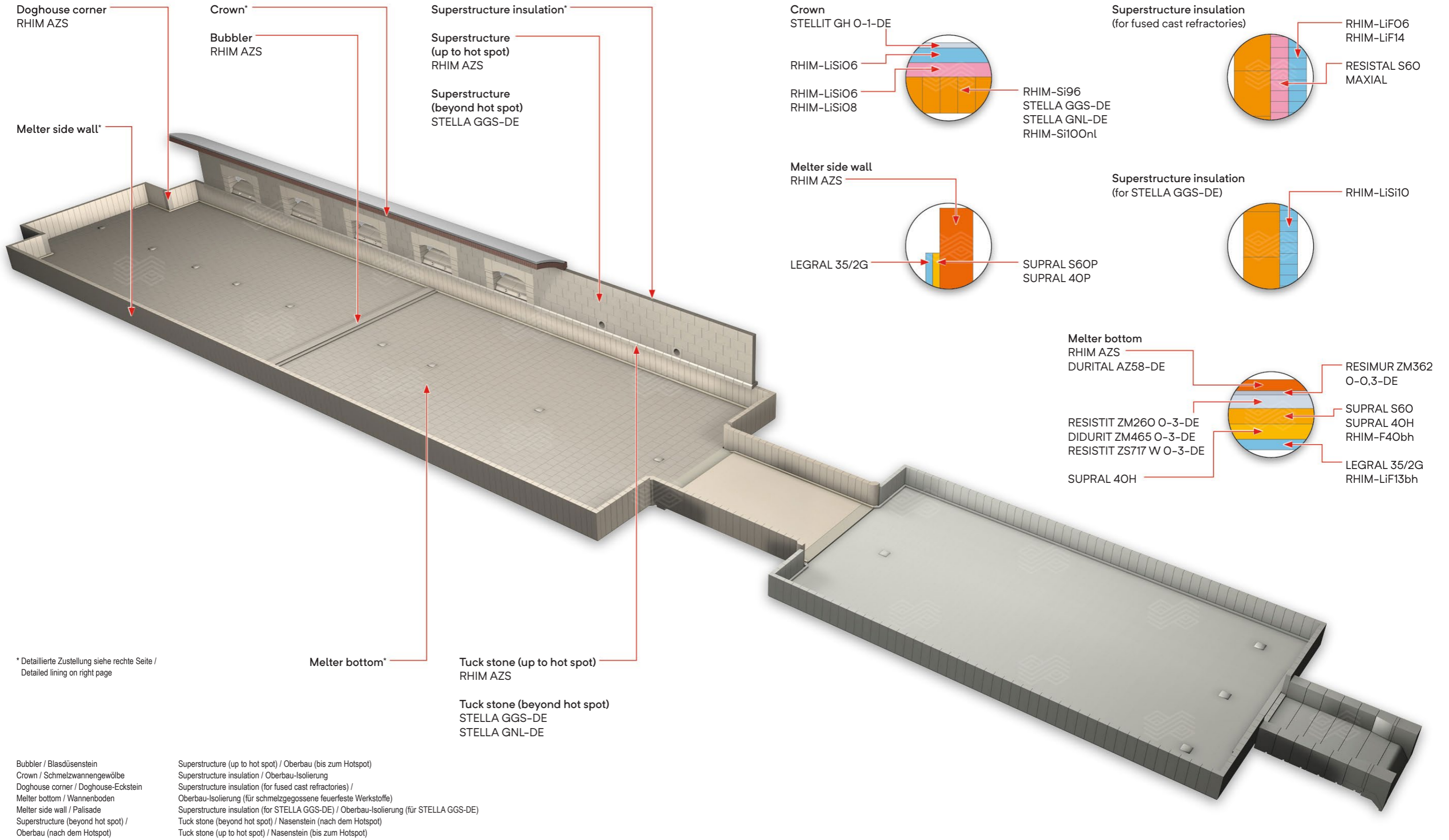

# Zinnbadboden

# Tin Bath Bottom

Hot bays  
SUPRAL CA  
RHIM-V4OFT

For the fixing holes  
DIDOFLO CA70-3-DE

Cold bays  
RHIM-V4OF

Cold bays / Kalter Arbeitsbereich  
For the fixing holes / Für die Befestigungslöcher  
Hot bays / Heißer Arbeitsbereich

Content	Lining	Lining	Shapes	Solutions	Bottom	Grades	Service

## Gehäuse

Die Wahl des Materials für das Regeneratorgehäuse hängt von verschiedenen Faktoren wie Anwendungstemperatur, Gemengestaub und Atmosphäre ab. Die Vorteile und Einschränkungen der unterschiedlichen Feuerfestmaterialien für Regeneratorgehäuse sind im Folgenden zusammengefasst:

### Mullit

- Bei sehr starker Gemengeverstaubung und niedrigerem Alkaligehalt im Abgas, steht eine große Auswahl an Mullit- und Andalusitsteinen zur Verfügung.
- Empfohlen für Regeneratoren in endbefeierten Wannen sowie die erste und zweite Kammer in kreuzbefeierten Wannen.

### Magnesia

- Magnesiasteine weisen eine hohe Beständigkeit gegenüber Alkaliangriff auf. Für Hochtemperatur- und Gewölbbeanwendungen ist eine Magnesiasorte mit niedrigem Druckfließen (z. B. ANKER DG10) zu empfehlen.
- Bei signifikanter Gemengeverstaubung können Magnesia-Zirkon-Steine (z. B. RUBINAL VZ) verwendet werden, insbesondere für die Prallwand.
- Ein Regeneratorgehäuse mit einem Magnesiagewölbe und -wänden weist das beste Preis-Leistungs-Verhältnis von allen Materialkonzepten auf.

### Silika

- Silika ist im Regeneratorgewölbe kosteneffizient und für Situationen mit signifikanter Gemengeverstaubung und hohen Abgastemperaturen (> 1470 °C) geeignet. Die Bildung von flüssiger Schlacke aufgrund von Alkaliangriffen ist bei niedrigeren Abgastemperaturen kritisch.
- Heutzutage ist Silika nicht die erste Wahl für Regeneratorkammern.

## Casing

The choice of regenerator casing material depends on multiple factors including the application temperature, carry-over, and atmosphere. The advantages and limitations of the various refractory materials for regenerator casings are summarized in the table below:

### Mullite

- In the case of very strong sand carry-over and lower alkali content in the flue gas, a large variety of mullite and andalusite bricks are available.
- Recommended for regenerators in endfired furnaces or the first and second chamber in crossfired furnaces

### Magnesia

- Magnesia bricks have a high resistance against alkali attack. For high-temperature and crown applications a magnesia grade with a low creep value (e.g., ANKER DG10) is recommended.
- In the case of significant sand carry-over, magnesia zircon (e.g., RUBINAL VZ) can be used, especially for the target walls.
- A regenerator casing comprising a magnesia crown and walls has the best cost-performance ratio of all the different material concepts.

### Silika

- Silika in the regenerator crown is cost-efficient and suitable for situations with significant sand carry-over and high flue gas temperatures (> 1470 °C). The formation of liquid slag due to the attack of alkalis is critical in the case of lower flue gas temperatures.
- Nowadays silica is not the first choice for regenerator casings.

Sorten in Grün: Zustellung mit basischen Steinen  
Sorten in blau: Zustellung mit Mullit

Grades in green: Lining with basic bricks  
Grades in blue: Lining with mullite

### Magnesia concept Crown and side walls

#### Crown & Upper Walls

T: 1250 – 1600 °C  
ANKER DG10  
RUBINAL VZ (Target wall)

#### Middle Walls

T: 800 – 1250 °C  
ANKER DG3

#### Lower Walls & Base

T: < 800 °C  
RHIM-F41  
RHIM-F40  
RHIM-F35  
MAXIAL 310

#### Rider arches

RESISTAL S65  
RHIM-S65

### Mullite Concept Crown and side walls

#### Crown & Upper Walls

T: 1550 – 1600 °C  
RHIM-S70+  
RHIM-M75f  
DURITAL E75EXTRA  
  
T: 1450 – 1550 °C  
RHIM S72  
DURITAL S70HM  
(1470 – 1550 °C)  
  
T: 1300 – 1450 °C  
RHIM-S65+  
DURITAL S65G

#### Middle Walls

T: 800 – 1425 °C  
RHIM-S65  
RHIM-S60  
  
T: 800 – 1300 °C  
RESISTAL S65  
RESISTAL S60

#### Lower Walls & Base

T: < 800 °C  
RHIM-F41  
RHIM-F40  
RHIM-F35  
MAXIAL 310

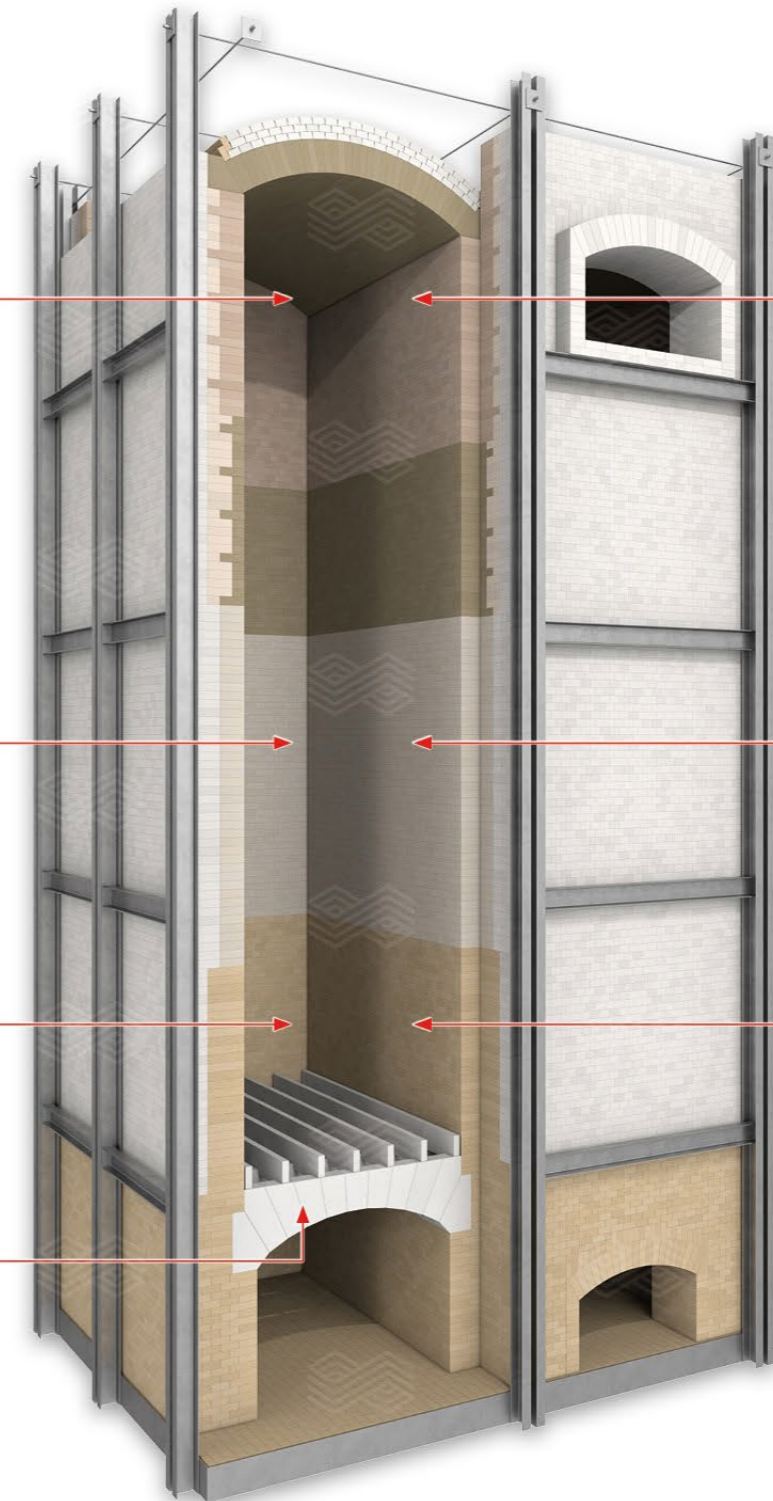

## INNOREG — Standardkonfiguration

Die Standardkonfiguration des INNOREG beinhaltet Gittersteinformate, die in Bezug auf Raumvolumen, Wandstärke und Wärmeübergangsfläche hin optimiert wurden, um eine maximale Effizienz des Regenerators zu ermöglichen

## INNOREG — Standard Configuration

The standard configuration of INNOREG includes checker brick shapes which have been optimized in terms of volume, wall thickness and heat transfer area to enable maximum efficiency of the regenerator.

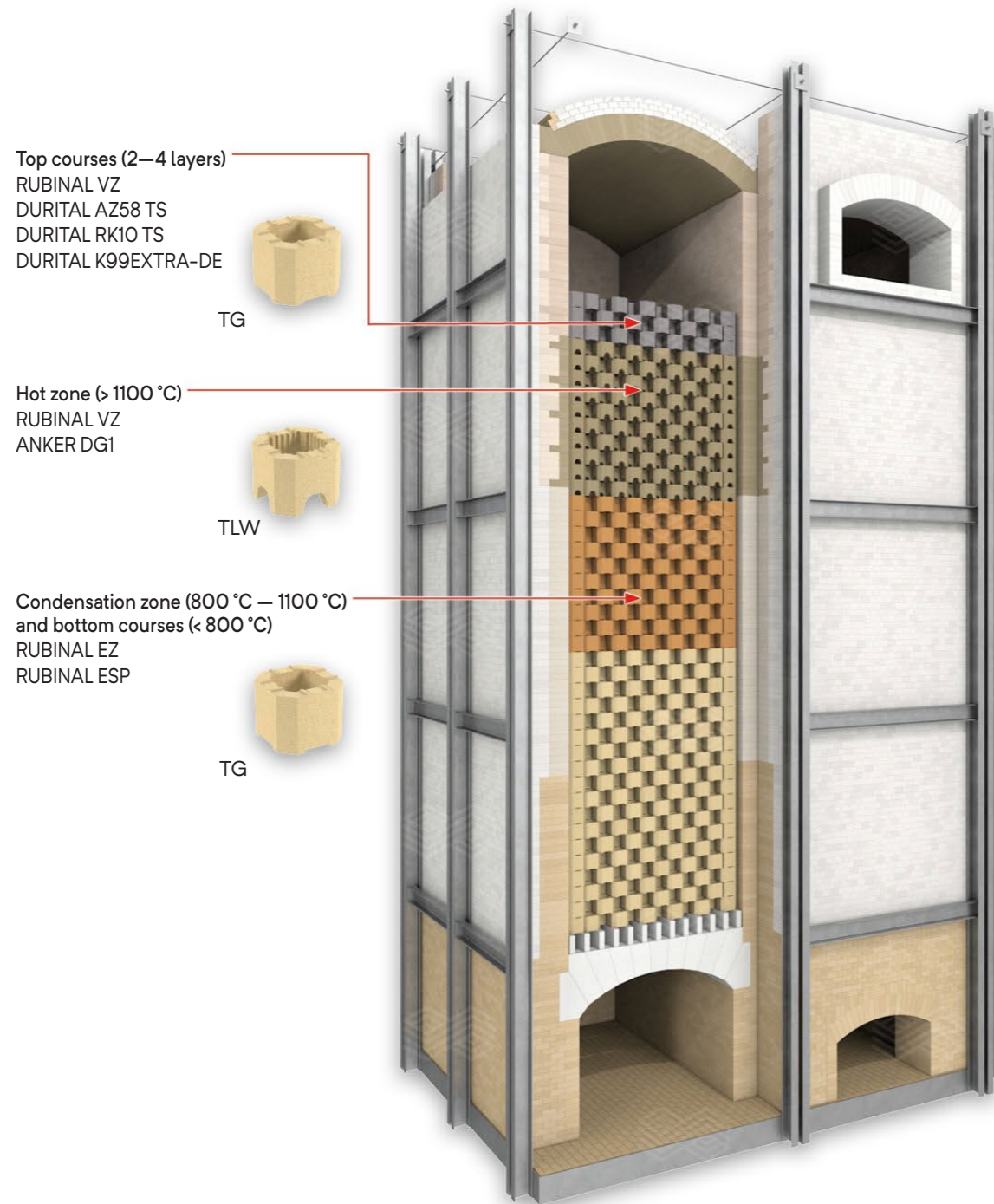

## INNOREG — Anti-Clogging Konfiguration

In manchen Regeneratoren gibt es ein erhöhtes Risiko für Verstopfungen. In solchen Regeneratoren können in der Kondensationszone Gittersteine eingesetzt werden, die eine doppelte Kanalweite ermöglichen. Dies verringert deutlich das Verstopfungsrisiko und erleichtert die thermische Reinigung.

## INNOREG — Anti-Clogging Configuration

Some regenerators have an increased clogging risk. In these regenerators, checker bricks which enable doubling the flue size can be used in the condensation zone. As a result, the risk of clogging is reduced significantly and thermal cleaning is facilitated.

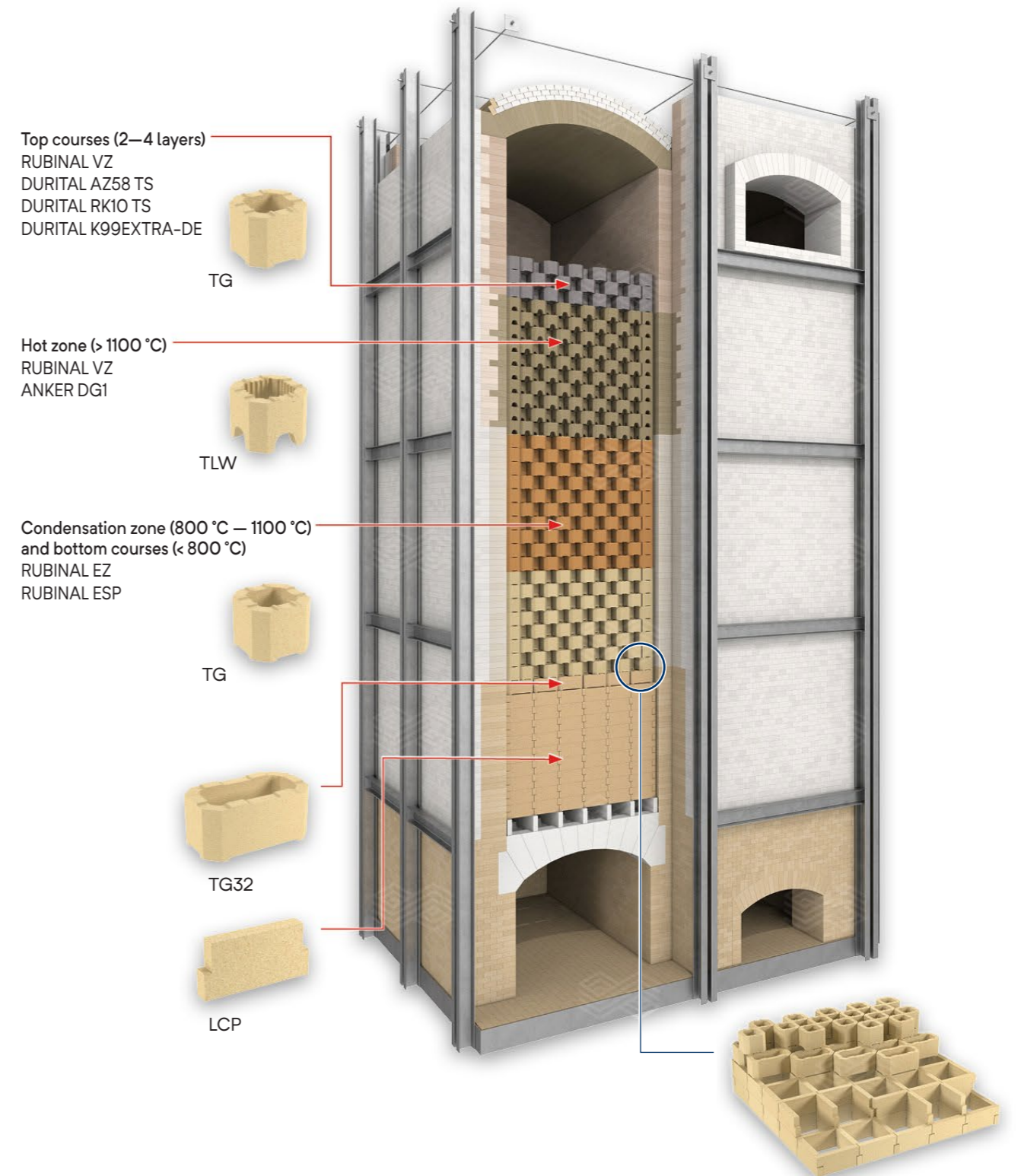

## Gittersteinformate

Ein wichtiger Faktor für die Effizienz von Regenerator Gittersteinen ist die spezifische Wärmeübergangsfläche.

Das TLW Format ist diesbezüglich optimiert. Die innere gewellte Oberfläche erhöht die spezifische Wärmeübergangsfläche auf 19 m<sup>2</sup>/m<sup>3</sup>.

Durch zwei weitere Formate kann eine größere Kanalweite erzielt werden, die eine Verstopfung in der Kondensationszone verhindern soll. Der lange Topfstein TG 32/175 ermöglicht die doppelte Kanalweite, der LCP („Large Channel Piece“) verfügt sogar über die vierfache Kanalweite im Vergleich zu Standardgittersteinen.

## Checker Brick Shapes

An important factor for the efficiency of regenerator checker bricks is the specific heat transfer area.

The TLW shape is optimized in this respect. The inner corrugated surface increases the specific heat transfer area to 19 m<sup>2</sup>/m<sup>3</sup>.

Two other shapes help achieve an increased flue size, which is intended to prevent clogging in the condensation zone. The long chimney block TG 32/175 provides double the flue size, while the flue size of the LCP („Large Channel Piece“) is even four times that of standard checker bricks.

Shape	Top Layer	Hot Zone		Condensation Zone	
Normal Conditions	TG	TLW	TL	TG	
Risk for Clogging	TG	TLW	TL	TG	TG 32/175 LCP

Shape	Flue size	Brick thickness	Brick height	Brick volume	Pieces	Specific heat transfer area
	mm					
TG 14/175	142	38	175	4.23	88.2	15.9
TG 15/175	150	30	175	3.40	88.2	17.0
TG 150/175	152	38	175	4.48	79.1	15.2
TG 17/175	170	40	175	5.22	64.8	13.9
TL 14/175	142	38	175	3.74	88.2	16.6
TL 15/175	150	30	175	3.02	88.2	17.1
TL 150/175	152	38	175	3.99	79.1	15.9
TL 17/175	170	40	175	4.51	64.8	14.2
TLW 14/175	142	38	175	3.46	88.2	18.9
TG32/175	322 x 142	38	175	6.54	44.1	13.2
LCP	310	50	175	2.89	88.2	9.6

Brick height / Steinhöhe  
Brick thickness / Steinstärke  
Brick volume / Steinvolumen

Flue size / Kanalweite  
Pieces / Stück  
Shape / Format

Specific heat transfer area /  
Spezifische Heizfläche

## Schlitzbogen und Tragsteine

Der Schlitzbogen dient als Basis zur Unterstützung der Gitterung. RHI Magnesita bietet hier zwei Konzepte an.

Das bewährte Standardkonzept beinhaltet Standardformate für den Bau von Schlitzbögen. Dies hat folgende Vorteile: Speziell designte Wölber (SB Formate) bilden einen scheinbaren Bogen, der ein solides Fundament für die Gitterung darstellt. Die Zustellung vor Ort wird einfacher.

### Einzelbögen

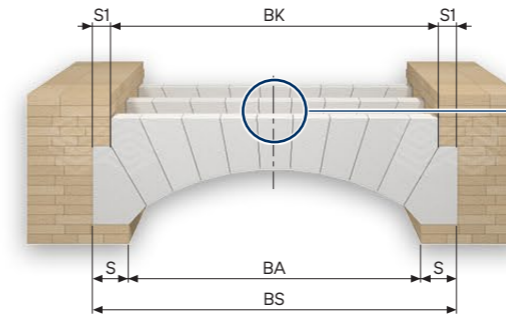

### Single arches

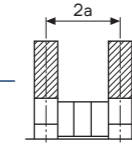

a = d + s  
d = Gitter-Kanalweite  
s = Gitterstein-Dicke

a = d + s  
d = Checker channel width  
s = Checker brick thickness

Chamber width	Width of waste gas flue	Rider arch width	Wall thickness		Pieces per rider arch															
			S	S1	SB 1	SB 2	SB 2A	SB 3	SB 3A	SB 4	SB 4A	SB 5	SB 6	SB 6A	SB 7	SB 7A	SB 8			
1150	900	1400	250	125	1		2		2								2			
1250	1000	1500	250	125	1		2	2									2			
1350	1100	1600	250	125	1	2		2									2			
1450	1200	1600	200	75	1	2		2									2			
1550	1300	1800	250	125	1		2		2				2						2	
1650	1400	1900	250	125	1	2			2				2						2	
1750	1500	2000	250	125	1	2			2				2						2	
1850	1600	2100	250	125	1	2			2				2						2	
1950	1700	2200	250	125	1		2		2				2	2						2
2050	1800	2300	250	125	1	2			2				2	2	2					2
2150	1900	2400	250	125	1	2			2				2	2						2
2250	2000	2500	250	125	1	2			2				2		2					2

## Kundenorientierte Systemlösungen — Keramischer Oberbau

Üblicherweise werden im Oberbau von Glasschmelzwannen schmelzgegossene AZS-Blöcke eingesetzt. Diese neigen dazu, bei hohen Temperaturen Glasphase „auszuschwitzen“, was zu Glasfehlern führen kann. Dieser Effekt wird noch ausgeprägter, wenn man neue Feuerungsalternativen wie Oxy-Fuel oder sogar H<sub>2</sub>-Feuerung in Betracht zieht.

RHI Magnesita bietet hier eine keramisch gebundene Alternative an, die kein solches Verhalten zeigt.

Empfohlen wird die Verwendung von Zirkonmullit-Steinen, DURITAL AZ58-DE, in dem vorderen Schmelzwannenbereich, insbesondere dort, wo mit Korrosion durch Verstaubungsprodukte zu rechnen ist. Im hinteren Bereich, wo ein Angriff durch Alkaliverdampfung vorherrscht, wird die Verwendung von DURITAL K99EXTRA-DE auf Edelmetallbasis empfohlen.

### Feuerfeste Steine / Refractory bricks

Grade	Al <sub>2</sub> O <sub>3</sub>	SiO <sub>2</sub>	ZrO <sub>2</sub>	BD	AP	CCS	TSR	RUL T <sub>0.5</sub>	TE	Raw material
	%	%	%	g/cm <sup>3</sup>	vol.%	N/mm <sup>2</sup>	Cycles	°C	1500 °C	
DURITAL K99EXTRA-DE	99.0	0.2		3.26	17.0	87	25	> 1700	1.20	Fused alumina
DURITAL AZ58-DE	59.0	13.5	25.0	3.20	14.5	134	> 30	1670	0.70	Sintered alumina, zirconia mullite, zirconium silicate
SUPRAL K99	98.0	0.5		3.20	18.5	110	15	1650	1.20	Fused alumina
SUPRAL AZ58	60.0	13.0	26.0	3.05	17.5	108	> 30	1680	0.65	Sintered alumina, zirconia mullite, zirconium silicate

AP Offene Porosität / Apparent porosity  
BD Rohdichte / Bulk density  
CCS Kaltdruckfestigkeit / Cold crushing strength  
RUL Druckerweichen / Refractoriness under load  
TE Wärmedehnung / Thermal expansion  
TSR Temperaturwechselbeständigkeit / Thermal shock resistance

Fused alumina / Schmelzkorund  
Grade / Sorte  
Raw material / Rohstoffbasis  
Sintered alumina / Sinterkorund  
Zirconia mullite / Zirkonmullit  
Zirconium silicate / Zirkoniumsilikat



DURITAL AZ58-DE Sample after two years field test



Silica crown is dripping on Superstructure blocks

## Customer-oriented System Solutions — Ceramic Superstructure

Fused cast AZS blocks are normally used in the superstructure of glass tanks. These blocks tend to exude glassy phase at high temperatures, which may lead to glass defects. This effect is getting more pronounced, when considering new firing alternatives like oxy-fuel or even H<sub>2</sub> firing

RHI Magnesita offers a ceramically bonded alternative which does not show such behavior.

The use of zirconia mullite bricks, DURITAL AZ58-DE, is recommended in the front area of the glass tank, especially where corrosion through dust products is to be expected. In the rear area, where attack through alkali evaporation prevails, the use of DURITAL K99EXTRA-DE based on white fused corundum is recommended.

## Komplexe Geometrien für spezielle Anwendungen

In einigen Positionen in der Glaswanne sind größere Blöcke mit komplexen Geometrien die beste technische Lösung. Gängige Beispiele sind Bauteile des Feeders oder größere Brennerblöcke.

Solche Geometrien sind durch Pressen oder Handstampfen nicht herstellbar. Vibrationsgießen kann diese Einschränkung überwinden. Mit dem Vibrationsgießen ist es möglich, -Blöcke mit einem Gewicht von 1 to und mehr zu produzieren. Formen mit einer Länge von mehr als 2 m und einer Höhe bis zu 400 mm sind möglich, ebenso wie die Abformung endkonturnaher komplexer Formate, die nach dem Entformen nur wenig Endbearbeitung benötigen.

Entsprechend den diversen Anforderungen in Glasöfen bietet RHI Magnesita ein Produktportfolio von mehreren Feuerfestsorten auf Basis von Zirkonmullit, Tonerde, Schmelzmullit, Andalusit, Zirkonsilikat und Chromkorund an.

## Complex Geometries for Special Applications

Larger blocks with complex geometries are the best technical solution in some locations of a glass tank. Common examples include components of the feeder or larger burner blocks.

These geometries cannot be produced by pressing or manual ramming. Vibration casting can overcome this limitation. Blocks weighing 1 ton or more can be produced using vibration casting. Shapes of a length of more than 2 m and a height of up to 400 mm are possible as well as the molding of near-net-shape complex shapes which require only little finishing after demolding.

In accordance with the diverse requirements in glass furnaces, RHI Magnesita offers a product portfolio of numerous refractory grades based on zirconia mullite, alumina, fused mullite, andalusite, zircon silicate and chrome corundum.

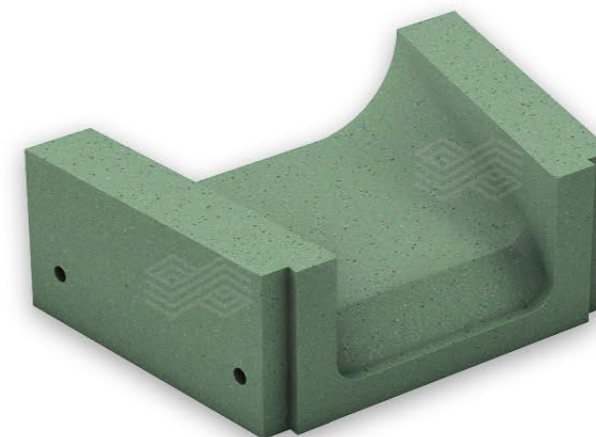

## Kundenorientierte Systemlösungen — Energieeffizienz

Einen entscheidenden Einfluss auf die Wärmeverluste eines Glasofens hat die Isolierung aller Bauteile, z. B. des Wannengewölbes. Stand der Technik sind hier minimalste Wärmeverluste von 1250 W/m<sup>2</sup> und weniger. Wegen der dadurch höheren Wannentemperatur (bis zu 1600 °C oder leicht darüber) ist zu beachten, dass nur Silikasteine mit herausragenden Druckfließigenschaften eingesetzt werden können.

Sehr niedrige Wärmeverluste lassen sich ohne aufwändige Installation erreichen, wenn man qualitativ hochwertige Silika-Isoliersteine verwendet.

## Customer-oriented System Solutions — Energy Efficiency

The insulation of all components, for example of the crown, has a crucial influence on the heat loss of a glass furnace. Minimal heat losses of 1250 W/m<sup>2</sup> or less are the state of the art here. Since the tank temperature is higher as a result (up to 1600 °C or slightly more) it must be noted that only silica bricks with outstanding creep under compression can be used.

Very low heat losses can be achieved without elaborate installation, when using high performance Silica insulation bricks.

Beispiel/Example:  
Gewölbezustellung mit Wärmeverlust < 1250 W/m<sup>2</sup>  
Crown lining concept with heat loss < 1250 W/m<sup>2</sup>

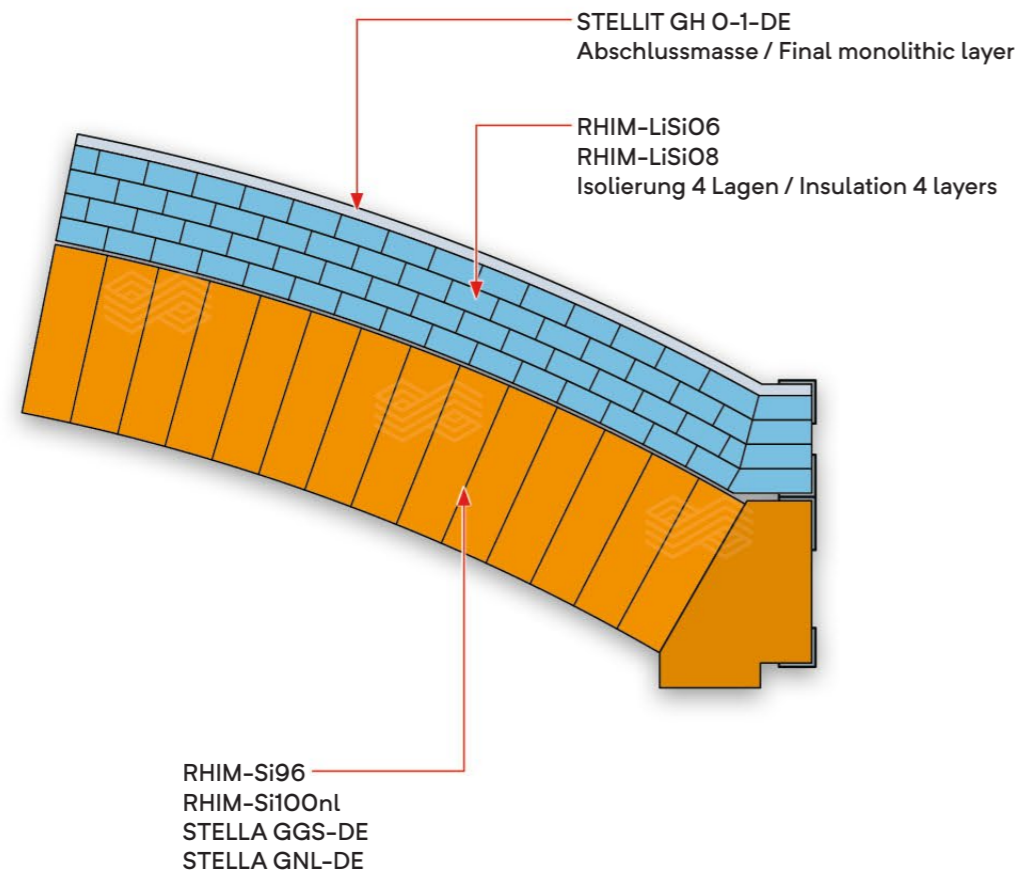

## Monolithisches Konzept

Ein weiteres fortschrittliches Konzept der Gewölbeisolierung verzichtet völlig auf Steinformate. Das monolithische Konzept besteht aus einer dichten Gewölbeversiegelung gefolgt von mehreren Lagen isolierender Leichtmassen.

Mit Hilfe von Wärmedurchgangsberechnungen kann die Dicke und Materialauswahl der einzelnen Lagen bestmöglich angepasst werden. Bei der Wahl der Leichtmassen wird jeweils die optimale Lösung im Bezug auf Temperaturbeständigkeit und Isolierfähigkeit bestimmt.

## Monolithic Concept

Another advanced concept of crown insulation completely does without brick shapes. The monolithic concept consists of a dense crown sealing followed by several layers of lightweight insulation mixes.

Using heat flux calculation, the thickness and material selection of the individual layers can be optimally adapted. When choosing the lightweight mixes, the optimum solution with regard to temperature resistance and insulation properties is determined.

Beispiel/Example:  
Gewölbezustellung mit Wärmeverlust < 1050 W/m<sup>2</sup>  
Crown lining concept with heat loss < 1050 W/m<sup>2</sup>

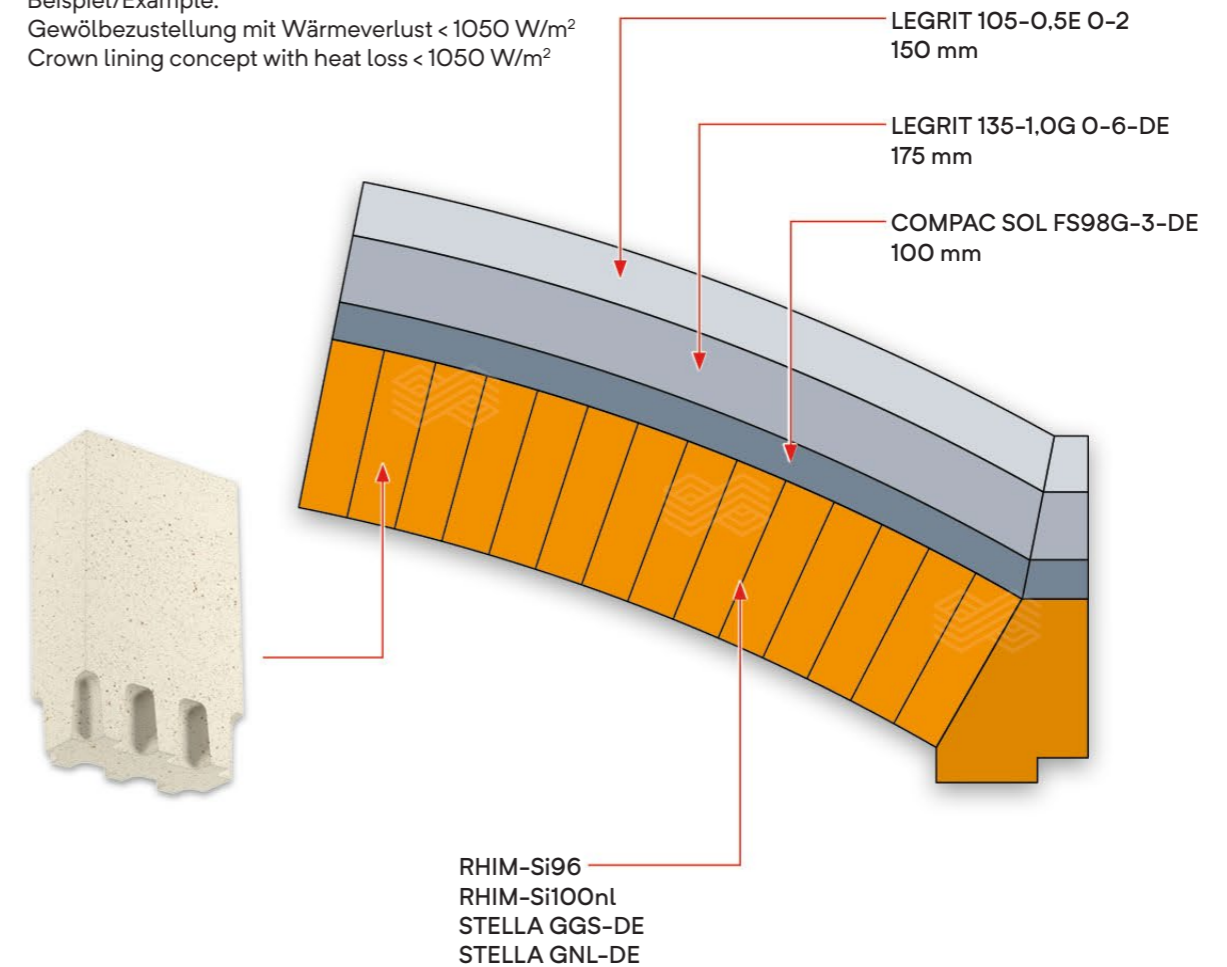

## Honeycomb Design

Die innovative Struktur der Wabensteine bildet eine strukturierte innere Gewölbeoberfläche, die durch einen physikalischen Effekt die Wellenlänge der vom Gewölbe reflektierten Wärmestrahlung moduliert. Infolgedessen ändert sich das Wärmeregime in der Ofenatmosphäre und es gelangt mehr Wärme in das Glasbad. Dies führt zu einem verbesserten Einschmelzen des Gemenges und einem geringeren Energieverlust über das Rauchgas. Es wurden Energieeinsparungen von bis zu 4 % beobachtet.

## Honeycomb Design

The ingenious designed structure of honeycomb wedges are forming a shaped inner crown surface which, by a physical effect, is modulating the wavelength of the heat radiation reflected by the crown. As a consequence the heat regime in the furnace atmosphere is changed and more heat is reaching the glass bath. This leads to improved batch down melting and reduced energy loss with the flue gas. Energy savings up to 4% were reported.



Speziell designte Wabensteine  
Specially designed honeycomb wedges

## Εpsilon-Konzept

Das Εpsilon-Konzept beinhaltet die Einfärbung des Silika-Materials. Dadurch wird der Emissionskoeffizient des Gewölbes erhöht, was zu einem höheren Wärmestrom vom Gewölbe in die Ofenatmosphäre führt, der mit einer etwas niedrigeren Gewölbetemperatur einhergeht. Mit dieser Technik können zusätzliche Energieeinsparungen in Bezug auf die strukturierte Oberfläche erzielt werden.

## Εpsilon Concept

The Εpsilon concept comprises the coloration of the silica material. As a consequence, the emission coefficient of the crown is increased. This leads to a higher heat flux from the crown to the furnace atmosphere correlated with a slightly lower crown temperature. Additional energy savings with regard to the structured surface can be realized with this technique.

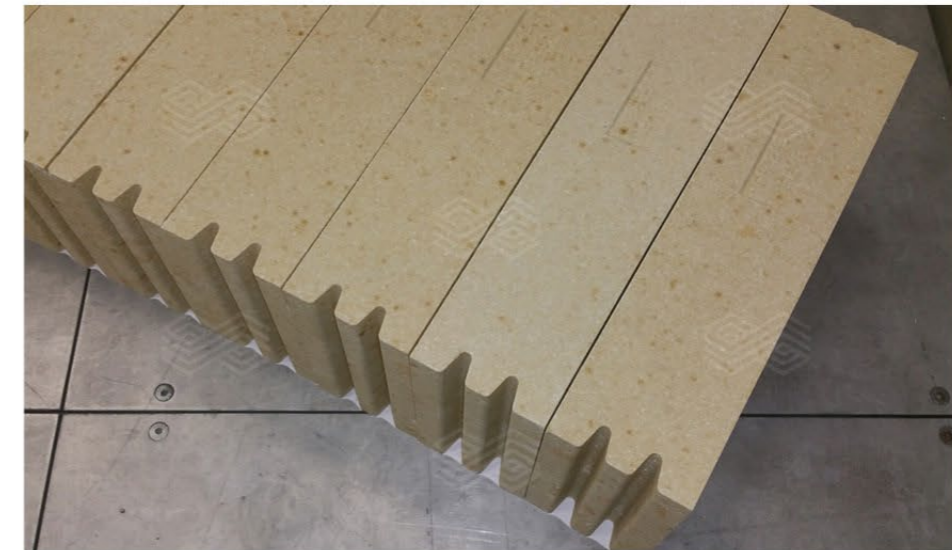

Gefärbte Silikasteine  
Colored Εpsilon wedges

## Boden Konzept

An den Schmelzboden werden, je nach Lage, unterschiedliche Anforderungen gestellt.

### Die oberen Lagen

**Die Bodenplatten** sind im Glaskontakt und müssen deshalb eine hohe Feuerfestigkeit und Korrosionsbeständigkeit gegen Glas aufweisen

- Schmelzgegossenes AZS; Chromkorund (für Faserglas)

**Die monolithische Lage** verhindert das Eindringen von Glasschmelze unter die Bodenplatten, um Blasenbohren vorzubeugen

- Geringe Schwindung beim Antempfern um Risse zu vermeiden
- RESIMUR 362; RESITECT SR391

**Die Sicherheitslage** verhindert das Metalltropfenbohren. Zirconosilikat basierte Sorten sind die Standardlösung. Sie schließen die Metalltropfen ein (Verkapselung)

- RESISTIT ZS 717W, RESISTIT ZS748 und ZETTRAL 65GG

Widerstand gegen Metalltropfenbohren; Chromkorund und Zirkonmullitsorten sind resistent gegen Metalltropfen

- DIDURIT ZM465, RESISTIT ZM260, DURITAL AZ58 und SUPRAL RK10P

Chromkorund Sorten für Faserglaswannen:

- SUPRAL RK30S, RESISTIT SR885 O-06

## Bottom Concept

The melter bottom is subject to different requirements according to each layer.

### The upper layers

**The bottom plates** are in contact with glass and therefore must have high fire resistance and corrosion resistance to glass

- Fused cast AZS; chrome corundum (for fiber glass)

**A monolithic layer** stops glass penetration through the paving joints and avoids upward drilling.

- Low shrinkage during heatup to obtain a sealed surface area
- RESIMUR ZM362; RESITECT SR391

**Safety Layer** prevents metal drop drilling. Zirconium silicate-based grades are the standard solution. They enclose the metal drops (encapsulation)

- RESISTIT ZS 717W, RESISTIT ZS748 and ZETTRAL 65GG.

Zircon mullite or chrome corundum grades are resisting to metal drop drilling

- DIDURIT ZM465, RESISTIT ZM260, DURITAL AZ58 and SUPRAL RK10P

Chrome corundum grades for the fiberglass melters:

- SUPRAL RK30S, RESISTIT SR885 O-06

### Die unteren Lagen

- Hitzebeständige, stützende und isolierende Lagen
- Feuerfestigkeit entsprechend den Schichttemperaturen
- Kriechwiderstand
- Einfache und schnelle Verlegung

### Temperatur-Profil

Die Sorte der unteren Schichten sollte entsprechend der zu erwartenden Temperatur festgelegt werden. RHI Magnesita kann den Kunden bei solchen Berechnungen unterstützen.

### Energie & Umwelt

Ungebrannte Bodenplatten mit hervorragendem CO<sub>2</sub>-Fußabdruck sind für jede Lage erhältlich

### The lower layers

- Heat resistant, supporting and insulating layers
- Refractoriness according to layer temperatures
- Creep resistance
- Easy and fast installation

### Temperature profile

The grade of the lower layers should be defined according to the expected temperature. RHI Magnesita can support the customer with such calculations.

### Energy & environment

Unfired bottom blocks with excellent CO<sub>2</sub> footprint are available for each layer.

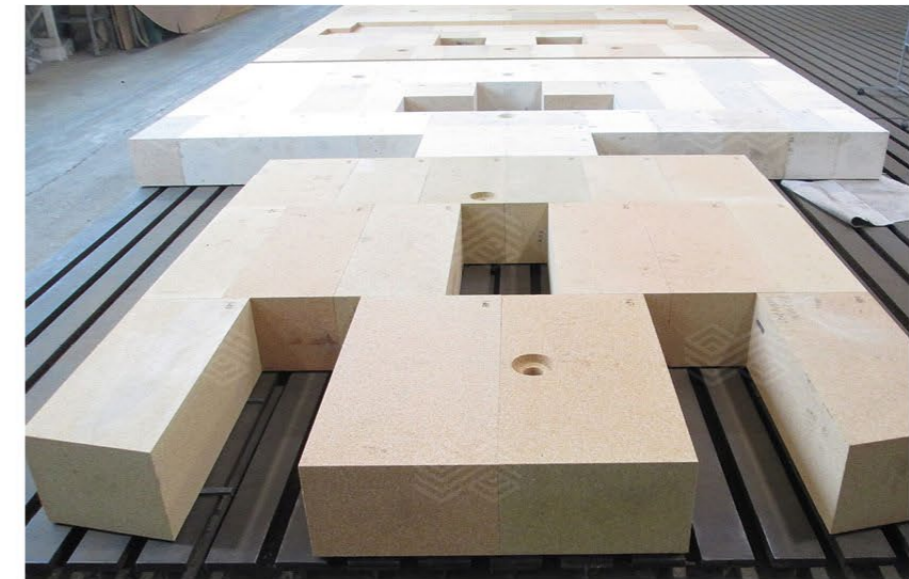
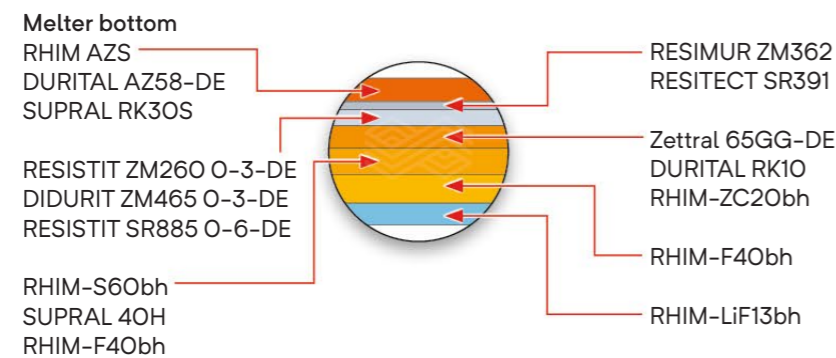

Komplizierte Formen, wie z.B. Thermoelement-, Abfluss- und Elektrodenblöcke, sind in den entsprechenden Qualitäten erhältlich.

Complicated shapes e.g. thermocouple, drain and electrode blocks are available on the respective grades.



Feuerfeste Steine / Refractory bricks

Grade	Al <sub>2</sub> O <sub>3</sub>	SiO <sub>2</sub>	Fe <sub>2</sub> O <sub>3</sub>	Cr <sub>2</sub> O <sub>3</sub>	CaO	MgO	ZrO <sub>2</sub>	BD	AP	CCS	TSR	RUL T <sub>0,5</sub>	TE	TC			Raw material	Mortars
	%	%	%	%	%	%	%	g/cm <sup>3</sup>	vol.%	N/mm <sup>2</sup>	H <sub>2</sub> O Cycles		1400 °C	500 °C	750 °C	1000 °C		
ANKER DG10		0.6	0.1		1.9	97.0		3.03	14.5	90		> 1700	1.95	7.7	5.9	4.6	High-grade sintered magnesia	ANKERFIX RP10
ANKER DG1		0.8	0.5		2.0	97.0		2.96	15.9	70		> 1700	1.95	7.7	5.9	4.6	High-grade sintered magnesia	ANKERFIX RP10
ANKER DG3		4.0	0.5		1.6	93.9		3.02	15.0	80		1600	1.95	7.7	5.9	4.6	Sintered magnesia	ANKERFIX RP10
RUBINAL EZ		10.5	0.5		1.2	73.7	14.0	3.10	14.5	90		1570	1.80	2.7	2.6	2.7	Sintered magnesia, zirconium silicate	ANKERFIX RP10
RUBINAL VZ		8.5	0.4		0.6	76.5	14.0	3.19	11.0	110		1670	1.80	2.7	2.6	2.7	High-purity sintered magnesia, zirconium silicate	ANKERFIX RP10
RUBINAL ESP	26.5	1.7	0.3		1.5	70.0		3.00	15.0	60		1590	1.40	5.0	4.8	4.6	High-purity sintered magnesia, MA-spinel	ANKERFIX RP10
ANKER DG10-CN		0.6	0.6		1.3	97.0		3.02	14.5	75		> 1700	1.95	7.7	5.9	4.6	High-purity sintered magnesia	ANKERFIX RP10 / ANKERFIX CRP
ANKER DG1-CN		0.6	0.6		1.5	97.0		2.90	16.0	80		> 1700	1.95	7.7	5.9	4.6	High-grade sintered magnesia	ANKERFIX RP10 / ANKERFIX CRP
ANKER DG3-CN		4.0	1.0		1.5	93.0		2.94	16.0	100		1600	1.95	7.7	5.9	4.6	Sintered magnesia	ANKERFIX RP10 / ANKERFIX CRP
ANKER DG6-CN		3.8			1.9	92.0		2.93	17.5	80		1560		7.7			Sintered magnesia	ANKERFIX RP10 / ANKERFIX CRP
RUBINAL EZ-CN		9.6	0.8		1.1	74.0	13.0	3.04	16.5	105		1570	1.80	2.7	2.6	2.7	Sintered magnesia, zirconium silicate	ANKERFIX RP10 / ANKERFIX CRP
RUBINAL VZ-CN		9.5	0.3		0.7	76.0	13.5	3.22	12.5	120		1680	1.80	2.7	2.6	2.7	Fused magnesia, zirconium silicate	ANKERFIX RP10 / ANKERFIX CRP
RUBINAL EF-CN	0.5	10.0	2.1		1.5	85.9		2.85	16.5	50		1570	1.40 (1200 °C)		5.9	4.6	Sintered magnesia	ANKERFIX RP10 / ANKERFIX CRP
ANKER DG10-BR	0.3	0.4	0.6		1.2	97.3		3.07	14.0	170		> 1700	1.95	7.7	5.9	4.6	High-grade sintered magnesia	ANKERFIX RP10-BR
ANKER DG1-BR		0.4	0.5		0.9	97.7		2.98	15.0	140		> 1700	1.95	7.7	5.9	4.6	High-grade sintered magnesia	ANKERFIX RP10-BR
ANKER DG3-BR		3.5	0.6		0.9	94.4		3.02	14.0	80		1680	1.95	7.7	5.9	4.6	Sintered magnesia	ANKERFIX RP10-BR
RUBINAL EZ-BR		9.5	0.5		0.8	75.0	13.0	3.12	13.0	90		1650	1.80	2.6	2.7	2.6	Sintered magnesia, zirconium silicate	ANKERFIX RP10-BR

Grade / Sorte  
 High-grade sintered magnesia /  
 Sintermagnesia hochwert  
 High-purity sintered magnesia, MA-spinel /  
 Sintermagnesia hochwert, MA-Spinell  
 Mortars / Mörtel  
 Raw material / Rohstoffbasis  
 Sintered magnesia / Sintermagnesia  
 Zirconium silicate / Zirkoniumsilikat

AP Offene Porosität / Apparent porosity  
 BD Rohdichte / Bulk density  
 CCS Kaltdruckfestigkeit / Cold crushing strength  
 RUL Druckerweichen / Refractoriness under load  
 TC Wärmeleitfähigkeit / Thermal conductivity  
 TE Wärmedehnung / Thermal expansion  
 TSR Temperaturwechselbeständigkeit /  
 Thermal shock resistance

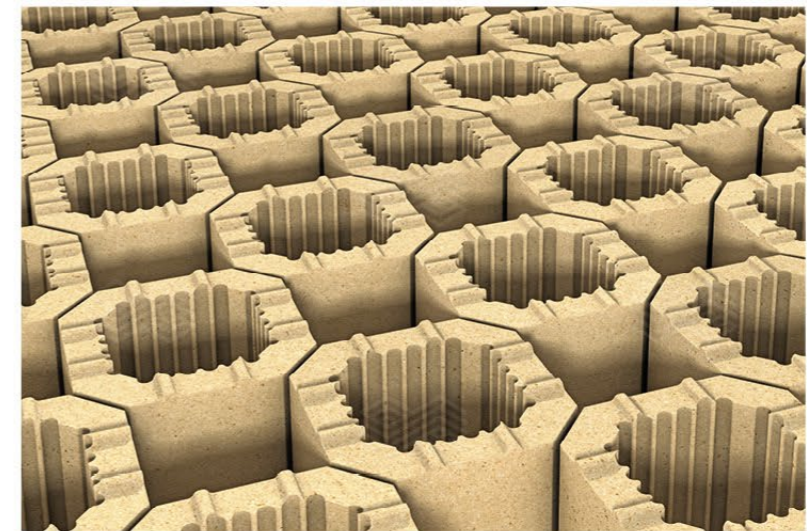
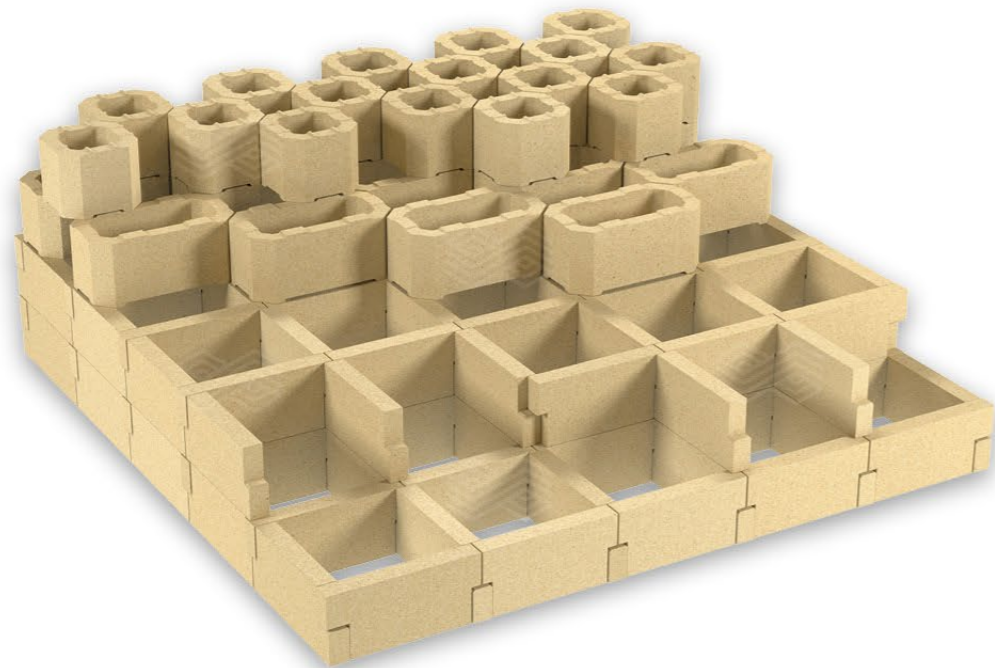

Die o.a. Werte stellen Richtwerte dar, die nach den geltenden Prüfnormen bzw. unternehmensinternen Methoden über einen längeren Zeitraum ermittelt wurden. Sie gelten jedoch nicht als verbindliche Spezifikationen und sind daher keinesfalls als ausdrückliche Zusicherung von bestimmten Eigenschaften zu verstehen. Technische Weiterentwicklungen und die Neuauflage von Datenblättern behalten wir uns vor.

The indicated values are standard values, i.e. values taken over a longer representative period of time according to either valid test standards or internal test methods. They may not be regarded as binding specifications and therefore not as guaranteed properties. We reserve the right to further technical developments and new editions of technical product information.

## Feuerfeste Steine / Refractory bricks

Grade	Al <sub>2</sub> O <sub>3</sub>	SiO <sub>2</sub>	Fe <sub>2</sub> O <sub>3</sub>	Cr <sub>2</sub> O <sub>3</sub>	CaO	MgO	ZrO <sub>2</sub>	BD	AP	CCS	TSR	RUL T <sub>0.5</sub>	TE	TC			Raw material	Mortars
	%	%	%	%	%	%	%	g/cm <sup>3</sup>	vol.%	N/mm <sup>2</sup>	H <sub>2</sub> O Cycles		°C	1400 °C %	500 °C W/m-K	750 °C W/m-K		
FONDAL SCW-DE		98.0						1.82	18.0	30	> 30	1600	0.10 (1000 °C)	1.0 (400 °C)	1.2 (800 °C)	1.2	Fused silica	STELLAMUR GLS 0-0,3-DE
RHIM-Si96	0.5	96.0	0.5		2.7			1.82	21	40		1675	1.35			2.1 (1200°C)	Quartzite	STELLAMUR GLS 0-0,3-DE
STELLA GNL-DE		98.5						1.90	16.0	45		1690	0.85 (600 °C)	1.3 (400 °C)	1.6 (800 °C)	1.8	Fused silica	STELLAMUR GLS 0-0,3-DE
RHIM-Si100nl		99.5						1.9	17	40		1690	1.3			2.1 (1400°C)		RHIM-Mt Si99
MAXIAL 310	42.0	54.0	1.2					2.23	17.0	50	25	1300	0.65 (1000 °C)	1.5 (400 °C)	1.5 (800 °C)	1.4	Fireclay	DIDOMUR 1 H 0-0,5-DE
MAXIAL 300	47.0	49.0	1.2					2.33	15.0	60	20	1400	0.58 (1000 °C)	1.5	1.8	2.0	Fireclay	DIDOMUR 1 H 0-0,5-DE
RESISTAL S60	61.5	36.5	0.8					2.53	15.0	103	> 50	1650	0.80	2.1 (400 °C)	1.8 (800 °C)	1.7 (1200 °C)	Andalusite	RESIMUR B64-05-DE
RESISTAL S65	63.5	34.5	0.7					2.56	15.2	60	> 30	1650	0.80	1.9 (400 °C)	1.8 (800 °C)	1.8	Andalusite	RESIMUR B64-05-DE <sup>1)</sup>
DURITAL S65G	63.0	34.5	0.7					2.55	14.3	107	> 30	1690	0.80 (1500 °C)	2.2 (400 °C)	2.2 (800 °C)	2.2	Andalusite	RESIMUR B64-05-DE
DURITAL S70	77.0	21.8	0.5					2.76	15.5	106	> 30	1700	0.80 (1500 °C)	2.5 (400 °C)	2.4 (800 °C)	2.3	Andalusite, fused alumina	RESIMUR M70-03-DE
DURITAL S70HM	69.2	69.3	0.5					2.64	15.0	75		1700	0.80 (1500 °C)	2.5 (400 °C)	2.4 (800 °C)	2.3	Andalusite, fused alumina	RESIMUR M70-03-DE
DURITAL E75EXTRA-DE	76.5	23.0	0.1					2.60	16.0	106	30	1700	0.75 (1500 °C)	2.0 (400 °C)	1.9 (800 °C)	2.0	Fused mullite	RESIMUR M70-03-DE
DURITAL K99EXTRA-DE	99.0	0.2	0.1					3.26	17.0	87	25	> 1700	1.20 (1500 °C)	4.7 (400 °C)	3.4 (800 °C)	2.9	Fused alumina	RESIMUR A98-05-DE
DURITAL RK10	85.0	0.8	0.6	10.5				3.33	15.5	150	15	> 1700	1.30 (1500 °C)	5.5 (400 °C)	4.1 (800 °C)	3.3	Chromium oxide, fused alumina	RESITECT SR391 0-0,3-BE
DURITAL RK10TS	85.5	1.0		10.5				3.30	16.5	175	15	> 1700	1.30 (1500 °C)	5.5 (400 °C)	4.1 (800 °C)	3.5 (1200 °C)	Chromium oxide, fused alumina	
DURITAL RK30NP	64.0	2.5		29.0			2.0	3.50	15.7	190	> 30	> 1700	1.20 (1500 °C)	4.1 (400 °C)	3.2 (800 °C)	3.1	Chromium oxide, fused alumina	RESITECT SR391 0-0,3-BE
DURITAL RK30NP Extra	64.0	2.5		29.0			2.0	3.47	12.2	120	>30	> 1701	1.20 (1500 °C)	4.2 (400 °C)	3.5 (800 °C)	3.2	Chromium oxide, fused alumina	RESITECT SR391 0-0,3-BE
DURITAL RK30S	61.0	2.5	0.5	30.0			2.8	3.47	13.5	200	25	> 1700	1.20 (1500 °C)	3.8 (400 °C)	3.1 (800 °C)	3.0	Chrome corundum fused grain, chromium oxide	RESITECT SR391 0-0,3-BE
DURITAL RK50NP	39.0	2.0	0.6	52.0			3.2	3.80	15.2	115	30	> 1700	1.20 (1500 °C)	3.7 (400 °C)	3.4 (800 °C)	3.3	Chrome corundum fused grain, chromium oxide	DIDOTECT K23PCR-03-BE
DURITAL RK50S	38.5	2.2		51.5			3.8	3.78	13.8	162	15	> 1700	1.20 (1500 °C)	3.7 (400 °C)	3.3	Chrome corundum fused grain, chromium oxide	DIDOTECT K23PCR-03-BE	
DURITAL RK70	16.0	3.8		72.0			4.0	3.90	15.0	150	15	1650	1.10 (1500 °C)	2.6 (400 °C)	2.4 (800 °C)	2.3	Chrome corundum fused grain, chromium oxide	DIDOTECT K23PCR-03-BE
DURITAL AZ50-DE	46.0	15.5					35.0	3.30	15.0	230	10	1650	0.70 (1000 °C)	3.5	3.1	2.8	AZS fused grain	RESIMUR ZM362 0-0,3-BE
DURITAL AZ58	59.0	13.5	0.1				25.0	3.20	14.5	134	> 30	1670	0.70 (1500 °C)	2.4 (400 °C)	2.1 (800 °C)	2.2	Sintered alumina, zirconia mullite, zirconium silicate	RESIMUR ZM362 0-0,3-BE
DURITAL AZ70-DE	70.0	10.5					17.5	3.33	14.5	140	20	1700	0.90 (1500 °C)	2.7 (400 °C)	2.4 (800 °C)	2.4	Fused alumina, zirconium silicate	RESIMUR ZM362 0-0,3-BE
ZETTRAL 65-DE	1.8	33.5	0.2				63.0	3.53	20.0	200	> 30	1590	0.45	2.8	2.6	2.4	Zirconium silicate	RESIMUR ZS716 0-0,3-BE
ZETTRAL 65GG-DE	1.2	33.0	0.1		0.2	0.1	64.0	3.67	19.0	130	30	1640	0.60	2.9 (400 °C)	2.3 (800 °C)	2.1	Zirconium silicate	RESIMUR ZS716 0-0,3-BE
ZETTRAL 65GS-DE		32.5					65.0	3.67	19.0	144	20	1640	0.60	2.5 (400 °C)	2.0 (800 °C)	2.0	Zirconium silicate	RESIMUR ZS716 0-0,3-BE
ZETTRAL 95GR		1.9				4.0	92.0	4.50	17.5	186	20	1650	0.80 (1600 °C)	1.3 (400 °C)	1.2 (800 °C)	1.1	Zirconia	RESIMUR ZS716 0-0,3-BE

Andalusite / Andalusit  
 AZS fused grain / AZS Schmelzkorn  
 Chrome corundum fused grain, chromium oxide /  
 Chrom-Korund-Schmelzkorn, Chromoxid  
 Cycles / Zyklen  
 Fireclay / Schamotte  
 Fused alumina / Schmelzkorund  
 Fused mullite / Schmelzmullit  
 Fused silica / Quarzglas

Grade / Sorte  
 Mortars / Mörtel  
 New name / Neuer Name  
 Quartzite / Quarzit  
 Raw material / Rohstoffbasis  
 Sintered alumina, zirconia mullite, zirconium silicate /  
 Sinterkorund, Zirkonmullit, Zirkoniumsilikat  
 Sintered magnesia / Sintermagnesia  
 Zirconia / Zirkonoxid

AP Offene Porosität / Apparent porosity  
 BD Rohdichte / Bulk density  
 CCS Kaldruckfestigkeit / Cold crushing strength  
 RUL Druckerweichen / Refractoriness under load  
 TC Wärmeleitfähigkeit / Thermal conductivity  
 TE Wärmedehnung / Thermal expansion  
 TSR Temperaturwechselbeständigkeit /  
 Thermal shock resistance

Die o.a. Werte stellen Richtwerte dar, die nach den geltenden Prüfnormen bzw. unternehmensinternen Methoden über einen längeren Zeitraum ermittelt wurden. Sie gelten jedoch nicht als verbindliche Spezifikationen und sind daher keinesfalls als ausdrückliche Zusicherung von bestimmten Eigenschaften zu verstehen. Technische Weiterentwicklungen und die Neuaufgabe von Datenblättern behalten wir uns vor.

The indicated values are standard values, i.e. values taken over a longer representative period of time according to either valid test standards or internal test methods. They may not be regarded as binding specifications and therefore not as guaranteed properties. We reserve the right to further technical developments and new editions of technical product information.

Content



Lining



Lining



Shapes



Solutions



Bottom



Grades



Service



## Großformatige Blöcke / Large-shaped blocks

Grade	Al <sub>2</sub> O <sub>3</sub>	SiO <sub>2</sub>	Fe <sub>2</sub> O <sub>3</sub>	Cr <sub>2</sub> O <sub>3</sub>	CaO	MgO	ZrO <sub>2</sub>	BD	AP	CCS	TSR	RUL T <sub>0,5</sub>	TE		TC			Raw material	Mortars
	%	%	%	%	%	%	%	g/cm <sup>3</sup>	vol.%	N/mm <sup>2</sup>	H <sub>2</sub> O		°C	%	500 °C	750 °C	1000 °C		
SUPRAL 40H	44.0	46.6	1.5		5.0			2.20	16.0	76.5		1250	0.40	1.3 (400 °C)	1.4 (800 °C)	1.4	Fireclay	DIDOMUR 1 H 0-0,5-DE	
SUPRAL S60	62.0	35.0	0.9					2.48	16.0	80	30	1650	0.80 (1400 °C)	2.0 (400 °C)	1.9 (800 °C)	1.9	Andalusite	RESIMUR B64-05-DE	
SUPRAL S70	77.0	21.0	0.4					2.66	19.0	85	> 30	1700	0.85 (1500 °C)	2.0 (400 °C)	1.9 (800 °C)	2.1	Andalusite, fused alumina	RESIMUR M70-03-DE	
SUPRAL E75	75.0	24.0	0.2					2.54	19.0	90	30	> 1700	0.70 (1400 °C)	1.9 (400 °C)	1.7 (800 °C)	1.6	Fused mullite	RESIMUR M70-03-DE	
SUPRAL K99	98.0	0.5						3.20	18.5	110	15	1650	1.20 (1500 °C)	5.4 (400 °C)	3.8 (800 °C)	3.4	Fused alumina	RESIMUR A98-05-DE	
SUPRAL AZ50	46.0	15.5					35.0	3.24	16.0	226	10	1660	0.65	2.5	2.4	2.3	AZS fused grain	RESIMUR ZM362 0-0,3-BE	
SUPRAL AZ58	60.0	13.0					26.0	3.05	17.5	108	> 30	1680	0.65 (1500 °C)	1.8 (400 °C)	1.7 (800 °C)	1.6	Sintered alumina, zirconia mullite, zirconium silicate	RESIMUR ZM362 0-0,3-BE	
SUPRAL AZ70	66.5	12.0					20.0	3.36	15.5	116	20	1650	0.90 (1500 °C)	2.9 (400 °C)	2.5 (800 °C)	2.4	Fused alumina, zirconium silicate	RESIMUR ZM362 0-0,3-BE	
SUPRAL RK30N	63.5	2.4		29.2				3.45	16.5	170	> 30	> 1700	1.10 (1500 °C)	2.9 (400 °C)	2.5 (800 °C)	2.5	Chromium oxide, fused alumina	RESITECT SR391 0-0,3-BE	
SUPRAL RK30S	61.5	1.7		30.8				3.45	16.0	200	25	> 1700	1.20 (1500 °C)	4.1 (400 °C)	3.3 (800 °C)	3.1	Chrome corundum fused grain, chromium oxide	RESITECT SR391 0-0,3-BE	
SUPRAL RK50S	37.0	2.2		53.0				3.77	14.2	140	25	> 1700	1.20 (1500 °C)	2.7 (400 °C)	2.4 (800 °C)	2.4	Chrome corundum fused grain, chromium oxide	DIDOTECT K23PCR-03-BE	
SUPRAL RK55S	42.0	0.8		52.0				3.80	15.3	140	25	1700	1.20 (1500 °C)	4.1	4.0	3.9	Chrome corundum fused grain, chromium oxide	DIDOTECT K23PCR-03-BE	
SUPRAL RK70	14.5	3.6		73.7				3.80	18.0	103	15	1700	1.10 (1500 °C)	3.0 (400 °C)	2.6 (800 °C)	2.5	Chrome corundum fused grain, chromium oxide	DIDOTECT K23PCR-03-BE	
RHIM-ZC20bh	59.0	18.0	0.2	2.7			19.0	2.90	19.0	45		1600	0.6 (at 1000°C)		2.2 (800 °C)	2.2 (1100 °C)	Sintered alumina, zirconia mullite, zirconium silicate		
RHIM-S60bh	61.0	33.0	0.8	2.3				2.50	17.0	65		1550	0.4 (at 1000°C)		1.9 (800 °C)	1.9 (1200 °C)	Andalusite		
RHIM-F40bh	42.0	51.0	1.8	<3.0				2.10	22.0	30		1360	0.5 (at 1000°C)		1.4 (800 °C)	1.5 (1100 °C)	Fireclay		
RHIM-LiF13bh	36.0	57.0	2.0	<3.0				1.35	40.0	10		1350*	0.3 (at 1000°C)	0.6 (400°C)	0.8 (800 °C)	0.9 (1100 °C)	Fireclay		

## Zinnbadboden Blöcke / Tin bath bottom blocks

Grade	Al <sub>2</sub> O <sub>3</sub>	SiO <sub>2</sub>	Fe <sub>2</sub> O <sub>3</sub>	Cr <sub>2</sub> O <sub>3</sub>	CaO	MgO	ZrO <sub>2</sub>	BD	AP	CCS	TSR	RUL T <sub>0,5</sub>	TE		TC			Raw material	Mortars
	%	%	%	%	%	%	%	g/cm <sup>3</sup>	vol.%	N/mm <sup>2</sup>	H <sub>2</sub> O		°C	%	500 °C	750 °C	1000 °C		
SUPRAL CA	68.0	5.0	0.1		24.4	1.3		2.36	18.0	80		1350	0.60	1.7	1.6	1.5	Calcium aluminate		
RHIM-V40F	43.0	52.0	1.2					2.20	20.0	30		1350	0.60						
RHIM-V40FT	40.0	56.0	1.4					2.15	21.0	40		1270	0.65						

## Vibrationsgegossene Blöcke / Vibrocast blocks

Grade	Al <sub>2</sub> O <sub>3</sub>	SiO <sub>2</sub>	Fe <sub>2</sub> O <sub>3</sub>	Cr <sub>2</sub> O <sub>3</sub>	CaO	MgO	ZrO <sub>2</sub>	BD	AP	CCS	TSR	RUL T <sub>0,5</sub>	TE		TC			Raw material	Mortars
	%	%	%	%	%	%	%	g/cm <sup>3</sup>	vol.%	N/mm <sup>2</sup>	H <sub>2</sub> O		°C	%	500 °C	750 °C	1000 °C		
FONDAL SXW	0.9	98.5						1.85	17.5	35	> 30	1600	0.10	1.3 (800 °C)	1.0 (400 °C)	1.5	Silica glass	STELLAMUR GLS 0-0,3-DE	
ANKOFORM F55F-6-DE	55.5	34.0	0.6		7.0			2.30	21.0	30		1380	0.55	1.8	1.8	1.8	Porcelain		
ANKOFORM S67F-6-DE	67.0	29.0	0.6		1.8			2.65	17.0	110	> 30	1700	0.60	2.3	2.2	2.2	Andalusite	RESIMUR B64-05-DE	
ANKOFORM M78F-6-DE	78.0	21.5	0.1		0.3			2.63	17.0	110	> 30	1700	0.50	2.3	2.2	2.2	Fused mullite	RESIMUR M70-03-DE	
ANKOFORM RK30ZF-6-DE	62.0	3.4		30.5	0.8		1.9	3.32	19.0	160	13	> 1700	0.77	2.6 (400 °C)	2.6 (700 °C)	2.5	Chrome corundum fused grain, chromium oxide	RESITECT SR391 0-0,3-BE	
ANKOFORM RK55ZF-6-DE	31.0	4.5		55.0	1.1		5.0	3.44	21.0	150	7	1700	0.77 (1100 °C)	3.2 (400 °C)	3.1 (700 °C)	3.0	Chrome corundum fused grain, chromium oxide	DIDOTECT K23PCR-03-BE	
ANKOFORM ZM33F-3-DE	51.0	15.0	0.1	0.5			33.0	3.10	18.0	100	> 30	1650	0.60	2.1	2.1	1.9	Zirconia mullite	RESIMUR ZM362 0-0,3-BE	

Andalusite / Andalusit  
AZS fused grain / AZS Schmelzkorn  
Calcium aluminate / Kalziumaluminat  
Chrome corundum fused grain, chromium oxide /  
Chrom-Korund-Schmelzkorn, Chromoxid  
Chromium oxide / Chromoxid  
Cycles / Zyklen  
Fireclay / Schamotte  
Fused alumina / Schmelzkorund  
Fused mullite / Schmelzmullit

Grade / Sorte  
Mortars / Mörtel  
Porcelain / Porzellan  
Raw material / Rohstoffbasis  
Silica glass / Quarzglas  
Sintered alumina, zirconia mullite, zirconium silicate /  
Sinterkorund, Zirkonmullit, Zirkoniumsilikat  
Zirconium silicate / Zirkoniumsilikat

AP Offene Porosität / Apparent porosity  
BD Rohdichte / Bulk density  
CCS Kaltdruckfestigkeit / Cold crushing strength  
RUL Druckenweichen / Refractoriness under load  
TC Wärmeleitfähigkeit / Thermal conductivity  
TE Wärmedehnung / Thermal expansion  
TSR Temperaturwechselbeständigkeit /  
Thermal shock resistance

Die o.a. Werte stellen Richtwerte dar, die nach den geltenden Prüfnormen bzw. unternehmensinternen Methoden über einen längeren Zeitraum ermittelt wurden. Sie gelten jedoch nicht als verbindliche Spezifikationen und sind daher keinesfalls als ausdrückliche Zusicherung von bestimmten Eigenschaften zu verstehen. Technische Weiterentwicklungen und die Neuaufgabe von Datenblättern behalten wir uns vor.

The indicated values are standard values, i.e. values taken over a longer representative period of time according to either valid test standards or internal test methods. They may not be regarded as binding specifications and therefore not as guaranteed properties. We reserve the right to further technical developments and new editions of technical product information.

Content



Lining



Lining



Shapes



Solutions



Bottom



Grades



Service



Hochtemperatur-Wärmedämmung / High-temperature heat insulation

Grade	ISO 2245	CT °C	Al <sub>2</sub> O <sub>3</sub> [MgO] %	SiO <sub>2</sub> %	Fe <sub>2</sub> O <sub>3</sub> [ZrO <sub>2</sub> ] %	CaO %	PLC %	BD g/cm <sup>3</sup>	CCS N/mm <sup>2</sup>		TE		TC				Mortars
											1000 °C %	400 °C W/m·K	600 °C W/m·K	800 °C W/m·K	1000 °C W/m·K	1200 °C W/m·K	
RHIM-LiSi06	150-0.6-L	1500	2.3	91.0		4.0		0.65	1.0		1.40	0.22	0.27	0.34	0.44		STELLAMUR GLS 0-0,3-DE
RHIM-LiSi08	155-0.8-L	1550	2.0	93.0		4.0		0.85	3.0		1.40	0.29	0.34	0.41	0.47		STELLAMUR GLS 0-0,3-DE
RHIM-LiSi10	160-1.0-L	1600	2.0	93.0		4.0		1.00	5.0		1.40	0.58	0.69	0.86	1.40		STELLAMUR GLS 0-0,3-DE
RHIM-LiSi12	155-1.2	1550	1.5	91.0		<6.5		1.25	4.5		1.40	0.66		0.83		1.13	STELLAMUR GLS 0-0,3-DE
RHIM-LiF06	125-0.6-L	1250	40.0	53.0	2			0.60	1.6		0.55	0.24	0.27	0.32	0.40	0.47	DIDOTECT Q21VC-05-DE
RHIM-LiF08	140-0.8-L	1400	54.0	41.0	1.4			0.80	3.5		0.60	0.33	0.36	0.39	0.43	0.47	DIDOTECT Q21VC-05-DE
RHIM-LiF10	150-1.0-L	1500	37.0	56.0	2.8			1.00	7.0		0.55	0.46	0.49	0.52	0.56		DIDOTECT Q21VC-05-DE
RHIM-LiF12	140-1.2	1400	37.0	55.0	2.9			1.18	12.0		0.55	0.54	0.56	0.58	0.60		DIDOTECT Q21VC-05-DE
RHIM-LiF13	135-1.3	1350	37.0	57.0	3.6			1.30	10.0		0.55	0.63	0.69	0.77	0.82		DIDOTECT Q21VC-05-DE
PYROSTOP ISOL 450	90-0.4-L	900	15.0	65.0	3.5	7.5	-1.00 (850 °C)	0.43	1.3		0.40 (900 °C)	0.12	0.14				DIDOTECT Q21VC-05-DE
PYROSTOP ISOL 600	90-0.5-L	900	15.0	65.0	3.5	7.5	-0.80 (850 °C)	0.50	2.5		0.40 (900 °C)	0.14	0.15				DIDOTECT Q21VC-05-DE
PYROSTOP BLANKET 96/1430		1430	35.0	50.0	[14.0]		-2.80 (1400 °C)	0.10				0.11	0.16	0.23	0.32		
PYROSTOP BOARD 1260		1250	46.1	53.9			-3.29 (1200 °C)	0.33					0.13	0.16	0.19		
PYROSTOP BOARD 1500		1500	60.0	39.0			-2.00 (1400 °C)	0.30				0.09	0.14	0.18	0.23	0.30	
PYROSTOP BOARD 1600		1600	65.0	34.0			-2.00 (1500 °C)	0.35				0.09	0.11	0.13	0.26	0.34	
PYROSTOP SUPERFELT 1400		1400	30.0	54.0	[16.0]		-2.00 (1400 °C)	0.25						0.15	0.21	0.29	
PYROSTOP SUPERFELT 1500		1500	59.0	40.0			-3.40 (1500 °C)	0.12							0.21	0.28	
PYROSTOP SUPERFELT 1600		1600	62.0	37.0			-3.00 (1600 °C)	0.17							0.21	0.23	

Grade / Sorte  
Mortars / Mörtel

BD Rohdichte / Bulk density  
CCS Kaltdruckfestigkeit / Cold crushing strength  
CT Klassifikationstemperatur / Classification temperature  
PLC Bleibende Längenänderung / Permanent linear change  
TC Wärmeleitfähigkeit / Thermal conductivity  
TE Wärmedehnung / Thermal expansion



PYROSTOP BLANKET

PYROSTOP BOARD

Die o.a. Werte stellen Richtwerte dar, die nach den geltenden Prüfnormen bzw. unternehmensinternen Methoden über einen längeren Zeitraum ermittelt wurden. Sie gelten jedoch nicht als verbindliche Spezifikationen und sind daher keinesfalls als ausdrückliche Zusicherung von bestimmten Eigenschaften zu verstehen. Technische Weiterentwicklungen und die Neuauflage von Datenblättern behalten wir uns vor.

The indicated values are standard values, i.e. values taken over a longer representative period of time according to either valid test standards or internal test methods. They may not be regarded as binding specifications and therefore not as guaranteed properties. We reserve the right to further technical developments and new editions of technical product information.

Feuerfeste Massen / Refractory mixes

Grade	Al <sub>2</sub> O <sub>3</sub>	SiO <sub>2</sub>	Fe <sub>2</sub> O <sub>3</sub>	CaO	ZrO <sub>2</sub>	MgO	P <sub>2</sub> O <sub>5</sub>	Cr <sub>2</sub> O <sub>3</sub>	TL	MR	CCS		PLC	TE	SL	TC			ML
	%	%	%	%	%	%	%	%	°C	kg/dm <sup>3</sup>	110 °C	1000 °C	1000 °C	1400 °C	Months	400 °C	600 °C	1000 °C	
												N/mm <sup>2</sup>	N/mm <sup>2</sup>	%	%		W/m·K	W/m·K	W/m·K
COMPRIT F44-6-DE	44.0	47.0	0.6	3.5		0.4			1350	2.15					12	0.9	0.9	1.0	Water
COMPRIT F47-6-DE	47.0	41.0	1.5	7.4					1400	2.10					12	0.7	0.7 (800 °C)	0.8 (1200 °C)	Water
COMPRIT B75-6-DE	73.5	19.0	1.3	3.6		0.2			1600	2.45				12	1.3	1.2	1.3	Water	
COMPRIT A95-3-DE	95.0	0.2	0.1	4.1		0.2			1800	2.70				12	2.6	2.1 (800 °C)	2.1	Water	
SUPER COMPRIT F41-6-DE	41.0	51.0	0.7	3.4					1400	2.20				8	0.9	1.0	1.1	Water	
DIDURIT F50-6-DE	51.0	44.0	1.0	1.6					1500	2.30				8	0.5	1.6 (800 °C)	1.8	Water	
STELLIT GH 0-1-DE	1.7	84.0	0.6	13.0					1400	1.85				12	0.3	0.4 (800 °C)	0.6 (1200 °C)	Water	
COMPAC SHOT SB FS99-3-DE	0.2	99.5	0.1						1650	1.80				18	1.1	1.3 (800 °C)	1.4	DIVASIL FP	
COMPAC SOL FS98G-3-DE	2.0	97.0	0.2	0.6					1550	1.75				18	1.1	1.3 (800 °C)	1.4	DIVASIL FP	
FONDIT H 0-6-DE	0.4	94.0	0.1	4.9		0.3			1650	1.80				8	1.6	1.9	2.0	Water	
FONDIT K 0-6-DE	0.4	99.0	0.1	0.1					1650	1.70				12	1.4	1.6	1.7	DIKASIL 2:1	
LEGRIT 105-0,5E 0-2	7.0	31.0	3.5	51.0		2.0			1050	0.55				12	0.2	0.2	0.2	Water	
LEGRIT 120-0,9 0-5-DE	37.0	37.0	3.0	19.0		0.5			1200	0.95				12	0.2	0.3	0.3	Water	
RESISTIT SR888 0-6-DE	86.5	1.0	0.3				3.4	8.5	1800	3.15				8	2.5	2.2 (800 °C)	2.2 (1200 °C)	Ready for use	
RESISTIT SR885 0-6-DE	67.0	0.5	0.1				3.0	29.0	1850	3.40				6	3.7	3.3 (800 °C)	2.8	Ready for use	
DIDURIT SR485 0-6-DE	67.0	2.0		1.2		0.2		27.0	1850	3.10				8	3.9	3.4 (800 °C)	3.0	Water	
COMPAC SOL RK61G-3-DE	28.0	5.0	0.7	1.1				61.0	1650	3.10				18	3.1	2.9	2.8	DIVASIL FP	
COMPAC SHOT RK64-3-DE	25.0	4.8	0.5					64.0	1800	3.40				8	2.9	2.7	2.6	Water	
RESISTIT ZS150P 0-3-DE	0.8	32.0	0.1		63.0		3.7		1650	3.75				12	1.4	1.2	1.0	Ready for use	
RESISTIT ZS748 0-3-DE	0.3	32.1	0.2		64.1		2.6		1800	3.83				12	1.4	1.2	1.0	Ready for use	
RESISTIT ZS748D 0-3-DE	0.5	32.5	0.2		64.0		2.5		1800	3.75				12	1.4	1.2	1.0	Ready for use	
RESISTIT ZS717 W 0-3-DE	1.3	31.0			65.0		0.1		1700	3.23				8	1.4	1.2	1.0	Ready for use	
RESISTIT ZM160P 0-1-DE	58.5	13.0	0.1		23.0		5.0		1600	3.30				12	1.8	1.6	1.4	Ready for use	
RESISTIT ZM260 0-3-DE	68.0	10.0	0.1		18.0		2.4		1650	3.00				12	1.9	1.7	1.5	Ready for use	
DIDURIT ZM465 0-3-DE	56.5	12.5	0.2	1.2	28.0				1600	3.05				12	1.6	1.5	1.4	Water	
DIDOFLO ZM30-3-DE	53.0	14.0	0.2	1.2	30.5				1600	3.05				12	1.6	1.5	1.4	Water	
DIDOFLO CA70-3-DE	70.0	5.0	0.1	14.0	9.2	1.2			1350	2.65				8	1.7	1.6	1.5	Water	
ANKERJET GW15-AT	1.9	5.3	0.8	2.8		88.6			1750					12				Water	

Grade / Sorte  
 Months / Monate  
 Ready for use / Verarbeitungsfertig  
 Water / Wasser

CCS Kaldruckfestigkeit / Cold crushing strength  
 ML Anmachflüssigkeit / Mixing liquid  
 MR Materialbedarf / Material requirement  
 PLC Bleibende Längenänderung / Permanent linear change  
 SL Lagerfähigkeit / Storage life  
 TC Wärmeleitfähigkeit / Thermal conductivity  
 TE Wärmedehnung / Thermal expansion  
 TL Anwendungsgrenztemperatur / Temperature limit of application

Die o. a. Werte stellen Richtwerte dar, die nach den geltenden Prüfnormen bzw. unternehmensinternen Methoden über einen längeren Zeitraum ermittelt wurden. Sie gelten jedoch nicht als verbindliche Spezifikationen und sind daher keinesfalls als ausdrückliche Zusicherung von bestimmten Eigenschaften zu verstehen. Technische Weiterentwicklungen und die Neuaufgabe von Datenblättern behalten wir uns vor.

The indicated values are standard values, i.e. values taken over a longer representative period of time according to either valid test standards or internal test methods. They may not be regarded as binding specifications and therefore not as guaranteed properties. We reserve the right to further technical developments and new editions of technical product information.



# Sorten

# Grades

## Feuerfeste Mörtel & Kitte / Refractory mortars & mastics

Grade	Al <sub>2</sub> O <sub>3</sub>	SiO <sub>2</sub>	Fe <sub>2</sub> O <sub>3</sub>	ZrO <sub>2</sub>	Cr <sub>2</sub> O <sub>3</sub>	MgO	TL	MR	SL	ML
	%	%	%	%	%	%	°C	kg/dm <sup>3</sup>	Months	
DIDOMUR S45-05-IN	46.0	49.0	1.2				1400	1.50	24	Water
DIDOMUR S60-05-IN	60.0	35.0	1.9				1400	1.60	24	Water
RESIMUR B64-05-DE	64.0	31.5	1.9				1550	1.65	24	Water
RESIMUR S70-05-IN	70.0	29.0	0.5				1650	1.60	12	Water
RESIMUR M70-03-DE	71.0	25.5	1.0				1650	1.55	12	Water
RESIMUR TC320 0-0,3-DE	86.0	11.0	0.2				1800	2.70	12	Water
RESIMUR A98-05-DE	97.5	1.5	0.1				1800	2.15	24	Water
DIDOTECT Q21VC-05-DE	21.5	72.0	1.2				1350	1.85	12	Ready for use
DIDOMUR Q23VC-05-DE	23.0	73.0	0.9				1350	1.40	12	DIKASIL 3:1
DIDOTECT B60VC-05-DE	49.5	42.0	1.8			0.2	1500	1.95	12	Ready for use
DIDOTECT B60VC-05-DE	60.0	32.5	1.5				1650	2.10	12	Ready for use
RESITECT K77V-05-DE	77.0	19.0	0.5				1800	2.25	12	Ready for use
RESITECT SR391 0-0,3-DE	66.5	1.7	1.0		29.0		1750	2.90	12	Ready for use
DIDOTECT K23PCR-03-DE	23.0	4.2			65.0		1870	3.45	9	Water
STELLAMUR GLS 0-0,3-DE	0.9	94.8	0.1				1680	1.30	24	Water
RHIM-Mt Si99	0.7	99.0	0.1				1680	1.40	24	Water
STELLATECT 150T 0-0,5-DE	1.1	96.0	0.2				1500	1.60	12	Water
RESIMUR ZS716 0-0,3-DE		37.5	0.3	60.0			1800	2.85	12	Water
RESIMUR ZM362 0-0,3-DE	49.0	16.5		31.0			1650	2.50	12	Water
ANKERFIX RP10-AT	0.1	1.0	0.2			95.6	1750	2.10	9	Water
ANKERFIX RP10-BR	0.4	1.6	0.6			94.4	1750	2.10	6	Water
ANKERFIX CRP-CN	0.2	0.8	0.8			94.5	1750	2.10	9	Water

Grade / Sorte  
Months / Monate  
Ready for use / Verarbeitungsfertig  
Water / Wasser

ML Anmachflüssigkeit / Mixing liquid  
MR Materialbedarf / Material requirement  
SL Lagerfähigkeit / Storage life  
TL Anwendungsgrenztemperatur / Temperature limit of application



Die o.a. Werte stellen Richtwerte dar, die nach den geltenden Prüfnormen bzw. unternehmensinternen Methoden über einen längeren Zeitraum ermittelt wurden. Sie gelten jedoch nicht als verbindliche Spezifikationen und sind daher keinesfalls als ausdrückliche Zusicherung von bestimmten Eigenschaften zu verstehen. Technische Weiterentwicklungen und die Neuauflage von Datenblättern behalten wir uns vor.

The indicated values are standard values, i.e. values taken over a longer representative period of time according to either valid test standards or internal test methods. They may not be regarded as binding specifications and therefore not as guaranteed properties. We reserve the right to further technical developments and new editions of technical product information.

# Toleranzen

# Tolerances

Grade	Tolerance	Warpage p (Brick length)	Taper difference
General (Machine-pressed bricks)	± 2.0 mm (≤ 100 mm) ± 1.5% (> 100 mm)	p ≤ 1.0 mm (≤ 350 mm) p ≤ 1.5 mm (> 350 mm)	± 1.5 mm (taper difference ≤ 19 mm) ± 2.0 mm (taper difference > 19 mm)
STELLA	Brick thickness ± 1.5 mm Other dimensions ± 2.0 mm	p ≤ 2.0 mm	± 1.0 mm (taper height ≤ 250 mm) ± 2.0 mm (taper height > 250 mm)
STELLA Ground wedges	Brick thickness ± 0.5 mm Other dimensions ± 2.0 mm	p ≤ 0.5 mm	± 0.5 mm
Regenerator checker (Except chimney block)	Brick thickness (< 100 mm) ± 2.0 mm Brick length (> 100 mm) ± 1.5% Brick height ± 0.5 mm	Standing face: p ≤ 0.5 mm (≤ 350 mm) p ≤ 1.0 mm (> 350 mm)  Side face: p ≤ 1.0 mm (≤ 350 mm) p ≤ 1.5 mm (> 350 mm)	
Regenerator checker (Chimney block)	Calibration groups + 2 = Brick height + 1 = Brick height 0 = Brick height - 1 = Brick height - 2 = Brick height	Tolerance + 1.5 mm to + 2.49 mm + 0.5 mm to + 1.49 mm + 0.5 mm to - 0.49 mm - 0.5 mm to - 1.49 mm - 1.5 mm to - 2.49 mm	
SUPRAL	+ 0 mm, - 2 mm	p ≤ 2.0 mm	
Unground plates	+ 1.5%	p ≤ 1.0 mm (≤ 350 mm) p ≤ 1.5 mm (> 350 mm)	

Brick height / Steinhöhe  
Brick length / Steinlänge  
Brick thickness / Steinstärke  
Calibration groups / Kalibrierte Gruppen  
Chimney block / Topfstein  
Except chimney block / Ausgenommen Topfsteine

Grade / Sorte  
Ground wedges / Geschliffene Wülber  
Machine-pressed bricks / Maschinengepresste Steine  
Other dimensions / Andere Maße  
Regenerator checker / Regenerator Gitterwerk  
Side face / Seitenfläche

Standing face / Standfläche  
Taper difference (Taper height) / Keilungsdifferenz (Keilhöhe)  
Tolerance / Toleranz  
Unground plates / Ungeschliffene Platten  
Warpage / Durchbiegung

Die Prüfungen erfolgen grundsätzlich am Einzelstein. Für Vormontagen müssen alle Angaben in gesonderten Zeichnungen festgehalten werden. Spezielle Toleranzen müssen abgestimmt und in den Zeichnungen vermerkt werden.

The tests are always carried out on individual bricks. For the purposes of preassembly, all the specifications must be provided in separate drawings. Special tolerances must be agreed upon and indicated in the drawings.



## Serviceangebote

RHI Magnesita bietet, zusammen mit einem professionellen Partnernetzwerk, Serviceaktivitäten rund um die Glaswanne an, die zum sicheren und fehlerfreien Ofenbetrieb sowie der Verlängerung der Lebenszeit beitragen.

### Analysen

Um einen Fehler erfolgreich beheben und in Zukunft zuverlässig verhindern zu können, ist zunächst seine Identifizierung unter Einsatz geeigneter Analyseverfahren nötig. RHI Magnesita verfügt über umfassendes Know-how in Umgang und Anwendung von zwei Analysethemen, die für Glashersteller und Ofenbetreiber entscheidend sind: Glasfehleranalyse und Feuerfestanalyse.

### Inspektionen

RHI Magnesita bietet weltweit mit seinem Partner spezialisierte Inspektionsservices für Behälter-, Flach- und Spezialglaswannen an: Visuelle Inspektion, Endoskopie, hochauflösende Thermografie (außen und innen) sowie videobasierte Langzeitüberwachung.

## Service Offers

In cooperation with a network of professional partners, RHI Magnesita offers service activities for glass tanks which contribute to safe and error-free furnace operation and to an extended service life.

### Analyses

In order to successfully eliminate defects and reliably prevent them in the future, such defects first have to be identified by using the appropriate analytical procedures. RHI Magnesita has comprehensive know-how in the application of two types of analysis which are crucial to glass producers and furnace operators: glass defect analysis and refractory analysis.

### Inspections

In cooperation with its partner, RHI Magnesita offers specialized inspection services for container glass, flat glass and special glass furnaces worldwide: visual inspection, endoscopy, high-resolution thermography (internal and external) and video-based long-term monitoring.

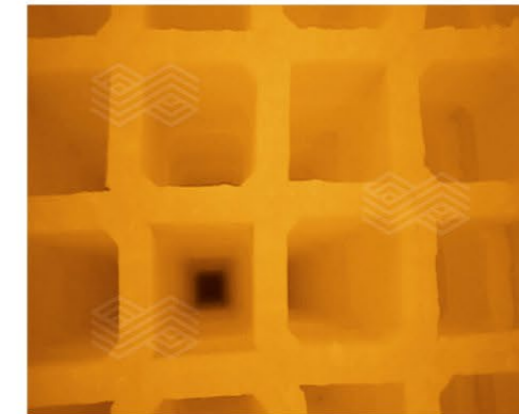

Darüber hinaus bietet RHI Magnesita seinen Kunden Unterstützung bei

- Technischen Fragestellungen
  - > Empfehlungen für Materialzustellungen mit optimiertem Preis-Leistungs-Verhältnis
  - > Wärmedurchgangsberechnungen
  - > Regeneratorberechnungen
  - > Feuerfestdesign
  - > Feuerfestbezogenen Glasfehleranalysen sowie Post-mortem-Analyse von Feuerfestmaterial
  - > After Sale Service
- Finanzierungsfragen
- Projektlogistik
- Notfällen
  - > Kurzfristiger Lieferung von Reparaturmaterialien durch Notfalllager
- Werkstoffrecycling

In addition, RHI Magnesita offers customers support in various areas:

- Technical questions
  - > Recommendations for a refractory lining with optimum price/performance ratio
  - > Heat flux calculations
  - > Regenerator calculations
  - > Refractory design
  - > Analysis of glass defects and post-mortem analysis of refractory material
  - > After sale service
- Financing questions
- Project logistics
- Emergencies
  - > Short-term delivery of repair material from emergency stocks
- Material recycling

Content



Lining



Lining



Shapes



Solutions



Bottom



Grades



Service



Imprint:

Media owner and publisher: RHI Magnesita N.V., Branch Vienna, Kranichberggasse 6, 1120 Vienna, Austria

Produced by: RHI Magnesita — 10 / 2024-DE/EN

Place of publication and production: Vienna, Austria



Copyright notice:

The texts, photographs and graphic design contained in this publication are protected by copyright. Unless indicated otherwise, the related rights of use, especially the rights of reproduction, dissemination, provision and editing, are held exclusively by RHI Magnesita. Usage of this publication shall only be permitted for personal information purposes. Any type of use going beyond that, especially reproduction, editing, other usage or commercial use is subject to explicit prior written approval by RHI Magnesita.

The Journal of  
Refractory Innovations  
**bulletin**

Subscriptions  
Service and  
Contributions



**RHI Magnesita**

Klingholzstraße 7, 65189 Wiesbaden, Germany

**T** +49 611 7335-0

**E** [glass@rhimaginesita.com](mailto:glass@rhimaginesita.com)

**[rhimaginesita.com](http://rhimaginesita.com)**